

BOX SERIES WORMGEAR UNITS

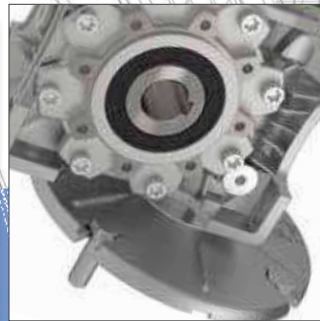



VISIT AND KNOW MOTIVE THANKS TO THE MOVIE ON WWW.MOTIVE.IT



Technical characteristics pag. 2-3



Efficiency - Irreversibility pag. 4

Mesh data pag. 5



Lubrication pag. 6

Mounting Position pag. 7



Technical data pag. 8

Configurator pag. 9



BOX performance tables pag. 10-11



BOX performance tables pag. 12-13

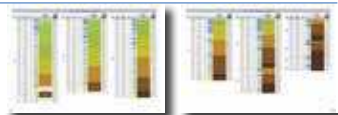

Stadio pag. 14

BOX+STADIO performance tables pag. 15



Dimensional tables pag. 16

BOX input and combinations pag. 17



STADIO+BOX combinations pag. 18

BOX general data pag. 19



Output flange pag. 20

Accessories pag. 21

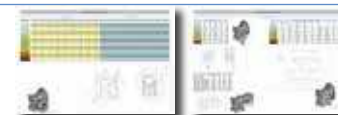

Components list pag. 22

Oil seal rings and bearings list pag. 23



Terms of sale and guarantee pag. 24



TECHNICAL CHARACTERISTICS

From type 75 and up, 2 taper roller bearings are mounted on the wormshaft, improving the mechanical resistance to the axial loads given by the wormwheel.

Moreover, the combination of this characteristic and 2 nilos (mounted on size 75 and up to keep lubrication grease inside the bearings even when they are not touched by the oil bath), or, in alternative, special RS shields on such taper bearings, permits the mounting of the whole BOX range, from the size 25 to the size 150, in the positions V5 and V6 without any need of additional interventions.



The housing shape has been studied to optimize the water draining during washing.



The new patented "BOX" series of worm gear units is made with die-casting aluminium housing from size 25 up to 90, and in cast iron from size 110.

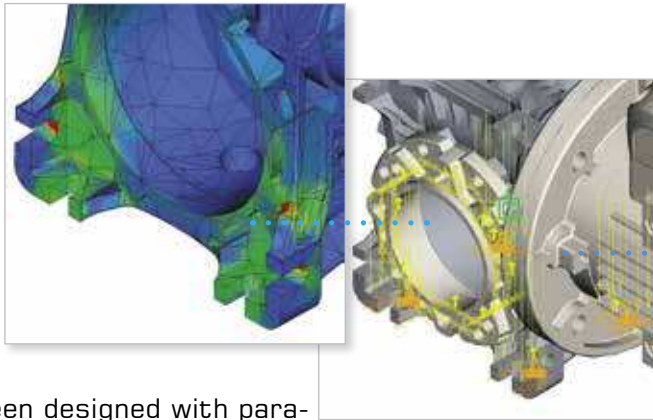

The housing has been designed with parametric three-dimensional CAD SW supported by programs of analysis of the thermal dissipation capacity and the structural resistance/deformation under the effect of working loads.

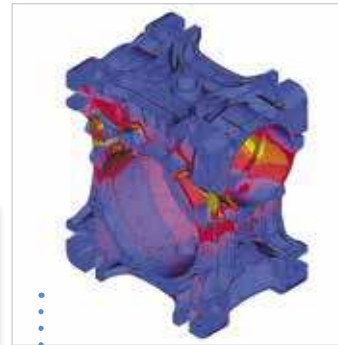

Mounting positions B6 or B7 are also permitted on all the BOX series, thanks to the adoption of 2RS auto-lubricated bearings on the output gear.

In conclusion, the whole BOX series can be mounted in any position with no need of specifications in the order.

TECHNICAL CHARACTERISTICS

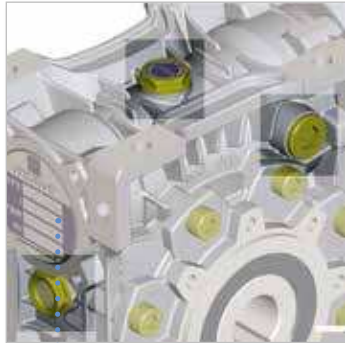

Lubrication is already provided by motive with long-life synthetic oil up to size BOX90, and with mineral oil from size BOX110.

The gear unit is equipped with a full set of filler, level and breather plugs, permitting all mounting positions and facilitating the management of the stock.



In order to increase silence, efficiency and duration, the wormshaft is made in case hardened steel and ground machined, while the worm wheel is in shell cast ZCuSn12 bronze.

The standard worm wheel hub is in spheroidal cast iron, an alloy that offers superior performance to grey cast iron and is suited also to heavy-duty use

An epoxy paint coat cancels the negative effects of the aluminium porosity and protects the housing from oxidation.

REGISTERED DESIGN



Made in an aluminum frame from size BOX25 to size BOX90, and in cast-iron from size BOX110 to size BOX150



2 safety plastic covers on the output are always provided to protect BOX during transportation and storage, and then the user from accidental contacts with moving parts

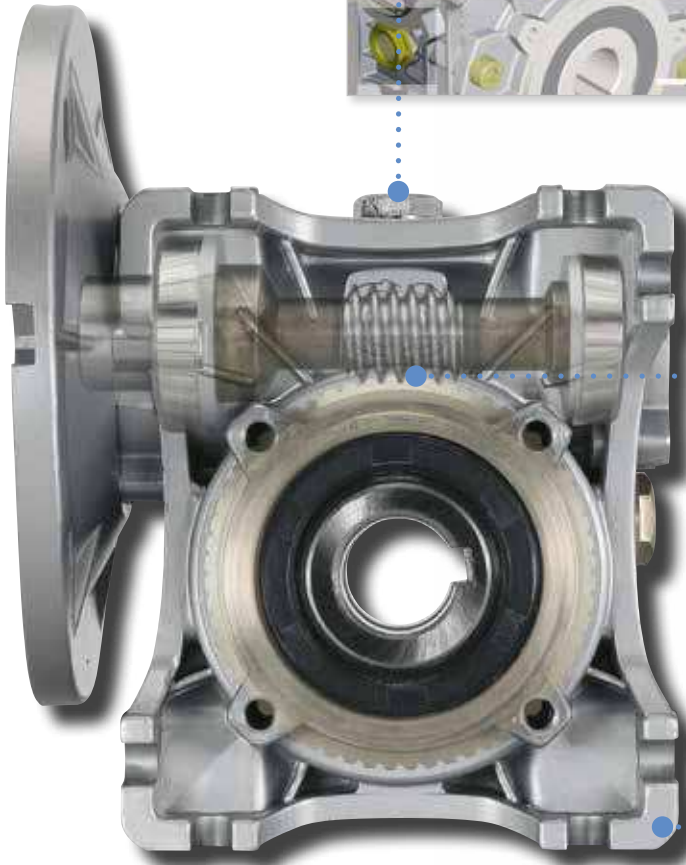

Mating surfaces are machined for a perfect planarity.



EFFICIENCY

An inherent factor in the selection wormgear boxes is the efficiency η , defined as the ratio between the mechanical power coming out from the output shaft, and the power in the input shaft:

$$\eta = \frac{P_{n2}}{P_{n1}}$$

Some reasons concurring to a reduction of the efficiency can be identified in the several forms of sliding and rolling friction.

In practice, efficiency depends essentially by:

- helix angle
- material of matching parts
- tooth form accuracy
- gear finishing
- lubrication
- gear sliding speed
- load vibrations
- temperature

In the combined BOX units (BOX+BOX), the total efficiency value is the result of the product of the efficiency of the two single boxes composing the combined unit.

Dynamic efficiency η_d

It is the efficiency value that comes out after completion of the running in time of a few hours and that keeps almost constant in the subsequent time of work.

The graph 1 shows indicatively the time required to reach the maximum value of dynamic efficiency

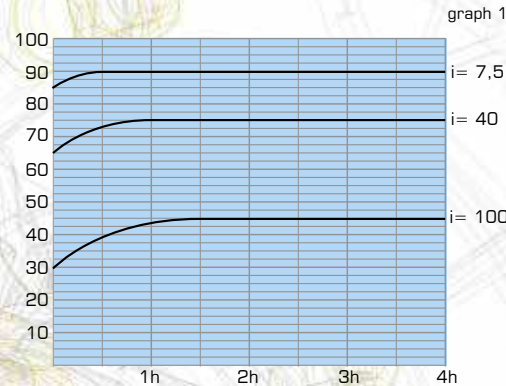

Static efficiency η_s

It is the efficiency obtained at start-up, particularly important in the choice of a BOX unit on those applications (like liftings) where due the very restricted time of work for each operation, the standard operating conditions are reached seldom. In these applications it is necessary to increase properly the motor power, in order to compensate the poor efficiency of the BOX unit while starting up ($\eta_s < \eta_d$).

IRREVERSIBILITY

Some BOX units permit to lock and hold in place a load when electric power switches off.

This characteristic, called irreversibility, is inversely proportional to the efficiency and the helix inclination, and directly proportional to the reduction ratio.

The efficiency of the toothing profiles is the main factor in effecting successfully the whole efficiency of the wormgear units, and it is on a large extent tied to the helix angle of profiles.

In order to get the fittest solution for a certain application, it is necessary to analyse the difference between static and dynamic irreversibility.

Static irreversibility

A BOX unit has a low static reversibility whenever it is possible to put it in rotation only through driving the output shaft with a very high torque and/or vibration or twisting of the output load. The static irreversibility is inversely proportional to the static efficiency. Theoretically:

$\eta_s < 50\%$	static irreversibility
$50\% < \eta_s < 55\%$	low static reversibility
$\eta_s \geq 55\%$	good static reversibility

Dynamic irreversibility

This is the most difficult condition to get. It occurs whenever, at the stop of the conditions keeping the worm shaft in rotation, even the motion of the output shaft stops immediately. The dynamic irreversibility is inversely proportional to the dynamic efficiency. Theoretically:

$\eta_d < 40\%$	total dynamic irreversibility
$40\% < \eta_d < 50\%$	good dynamic irreversibility
$50\% < \eta_d < 60\%$	low dynamic reversibility
$\eta_d \geq 60\%$	good dynamic reversibility

The table 1 proposes an indicative analysis of the different degrees of irreversibility based on the helix angle.

Note: Whenever a total irreversibility of a BOX unit is important for safety reasons, we strongly recommend the use of brake motors of the AT Delphi series.

MESH DATA

type	i	7,5	10	15	20	25	30	40	50	60	80	100
BOX 025	Z ₁	3	3	2	2		1	1	1	1		
	Z ₂	24	30	30	38		30	38	47	60		
	β	16° 41' 57"	16° 41' 57"	11° 18' 36"	9° 27' 44"		5° 42' 38"	4° 45' 49"	3° 41' 29"	2° 27' 15"		
	m _x	1,5	1,25	1,25	1		1,25	1	0,8	0,6		
	η _d (1400)	85,90%	83,20%	78,00%	75,90%		65,30%	62,50%	54,80%	53,80%		
BOX 030	Z ₁	4	3	2	2	2	2	1	1	1	1	
	Z ₂	30	30	30	40	50	30	40	50	60	80	
	β	18° 48' 58"	14° 20' 8"	9° 40' 7"	7° 42' 13"	5° 42' 38"	4° 52' 9"	3° 52' 10"	3° 15' 37"	2° 13' 37"	2° 6' 36"	
	m _x	1,44	1,44	1,44	1,10	1,75	1,44	1,10	0,90	0,70	0,56	
	η _d (1400)	82,00%	80,70%	72,60%	72,00%	68,00%	62,00%	55,00%	52,00%	46,00%	40,00%	
BOX 040	Z ₁	4	3	2	2	2	1	1	1	1	1	1
	Z ₂	30	30	30	40	50	30	40	50	60	80	100
	β	24° 28' 25"	18° 50' 51"	12° 49' 17"	10° 29' 51"	8° 45' 5"	6° 29' 31"	5° 17' 36"	4° 24' 5"	3° 47' 4"	2° 56' 9"	2° 28' 53"
	m _x	2	1,5	2	1,5	2,5	2	1,5	1,25	1	0,75	0,65
	η _d (1400)	87,30%	85,30%	81,00%	78,00%	75,00%	69,70%	65,00%	62,00%	56,00%	50,00%	0,485
BOX 050	Z ₁	4	3	2	2	2	1	1	1	1	1	1
	Z ₂	30	30	30	40	50	30	40	50	60	80	100
	β	23° 57' 45"	18° 26' 6"	12° 31' 43"	10° 18' 17"	8° 35' 51"	6° 20' 25"	5° 11' 40"	4° 24' 5"	3° 41' 53"	2° 51' 45"	2° 17' 26"
	m _x	2,5	2	2,5	2	1,5	2,5	2	1,5	1,25	1	0,75
	η _d (1400)	89,00%	87,50%	81,80%	80,20%	75,20%	70,60%	68,30%	61,30%	57,90%	52,80%	46,00%
BOX 063	Z ₁	4	3	2	2	2	1	1	1	1	1	1
	Z ₂	30	30	30	40	50	30	40	50	60	80	100
	β	25° 50' 36"	19° 57' 51"	13° 36' 49"	10° 53' 8"	8° 44' 46"	6° 30' 20"	5° 29' 32"	4° 23' 55"	3° 56' 43"	3° 5' 17"	2° 26' 1"
	m _x	3	2,5	3	2,5	2	3	2,5	2	1,75	1,25	1
	η _d (1400)	89,10%	88,60%	82,40%	81,80%	79,70%	73,00%	70,60%	67,50%	64,50%	57,90%	51,10%
BOX 075	Z ₁	4	3	2	2	2	1	1	1	1	1	1
	Z ₂	30	30	30	40	50	30	40	50	60	80	100
	β	26° 38' 16"	20° 36' 57"	14° 4' 5"	11° 18' 36"	10° 18' 18"	7° 8' 51"	5° 42' 38"	5° 11' 40"	4° 20' 31"	3° 24' 42"	2° 51' 45"
	m _x	4	3	3,75	3	2,5	3,75	3	2,5	2	1,5	1,25
	η _d (1400)	91,00%	89,60%	85,20%	83,50%	81,90%	75,80%	73,80%	70,70%	65,50%	59,00%	56,50%
BOX 090	Z ₁	4	3	2	2	2	1	1	1	1	1	1
	Z ₂	30	30	30	40	50	30	40	50	60	80	100
	β	29° 11' 11"	22° 43' 48"	15° 36' 15"	13° 1' 15"	11° 18' 36"	7° 56' 58"	6° 35' 44"	5° 42' 38"	4° 45' 49"	3° 52' 55"	3° 7' 20"
	m _x	4,5	3,5	5	3,5	3	5	3,5	3	2,5	1,75	1,5
	η _d (1400)	91,30%	89,90%	88,20%	84,10%	83,50%	80,80%	74,00%	73,10%	69,60%	61,40%	59,00%
BOX 110	Z ₁	4	3	2	2	2	1	1	1	1	1	1
	Z ₂	30	30	30	40	50	30	40	50	60	80	100
	β	28° 14' 32"	21° 56' 32"	15° 1' 59"	14° 48' 14"	12° 59' 41"	7° 38' 54"	7° 31' 39"	6° 34' 55"	5° 48' 8"	4° 27' 28"	3° 52' 55"
	m _x	6	4,5	6	4,5	3,5	6	4,5	3,5	3	2,25	1,85
	η _d (1400)	92,40%	91,20%	88,40%	86,10%	83,80%	81,00%	77,20%	73,50%	72,00%	66,00%	63,00%
BOX 130	Z ₁	4	3	2	2	2	1	1	1	1	1	1
	Z ₂	30	30	30	40	50	30	40	50	60	80	100
	β	29° 14' 56"	22° 46' 57"	15° 38' 32"	13° 47' 27"	11° 53' 34"	7° 58' 11"	6° 59' 48"	6° 0' 40"	5° 16' 6"	4° 23' 55"	3° 34' 35"
	m _x	7	7	7	5,4	4,37	7	5,4	4,37	3,67	2,75	2,75
	η _d (1400)	90,00%	86,00%	84,00%	83,00%	81,00%	79,00%	75,00%	72,00%	70,00%	65,00%	62,00%
BOX 150	Z ₁	6	4	3	2	2	2	1	1	1	1	1
	Z ₂	45	40	45	40	50	60	40	50	60	80	100
	β	32° 54' 19"	25° 29' 51"	17° 55' 41"	13° 24' 45"	11° 18' 36"	9° 55' 34"	6° 47' 58"	5° 42' 38"	5° 0' 2"	4° 9' 35"	3° 37' 43"
	m _x	5,5	6,2	5,5	6,2	5	4,2	6,2	5	4,2	3,2	2,6
	η _d (1400)	90,00%	86,00%	84,00%	83,00%	81,00%	79,00%	75,00%	72,00%	70,00%	65,00%	62,00%
η _s	72,00%	66,67%	61,53%	60,54%	56,89%	48,00%	46,15%	42,24%	39,09%	34,40%	31,29%	



- Z₁ nr of starts of the worm
- Z₂ nr of wormwheel teeth = Z₁ · i
- β helix angle
- m_x normal module
- η_d(1400) dynamic efficiency with n₁ = 1400rpm
- η_s static efficiency

tab. 1

	irreversibility	
	dynamic	static
β > 20°	total reversibility	
10° < β < 20°	high dynamic reversibility	almost total reversibility, quick return
8° < β < 10°	high dynamic reversibility, low irreversibility	quick return
5° < β < 8°	low dynamic reversibility, but easy in case of vibrations	good reversibility and poor self-locking
3° < β < 5°	low dynamic reversibility, good irreversibility	very low reversibility and good irreversibility
1° < β < 3°	total irreversibility	

LUBRICATION

Unless otherwise specified, BOX units sizes 25 up to 90 are supplied with long-life lubrication and they don't require any maintenance.

BOX110, BOX130 and BOX150 are already pre-lubricated as well, with mineral oil VG460.

The use of oil instead of grease offers remarkable improvements under the point of view of the application, especially in the effectiveness and efficiency of the lubrication in the "limit layer" condition as well as under high intermittence applications.

Furthermore, synthetic oil lubrication assures a much wider range of low and high operating temperatures.

With the use of synthetic oil, the temperature limits turn out to be determined by the properties of the seal material as well as the thermal expansion of the frame material.

All units are supplied with plugs for loading, discharging and checking the level of the oil. Furthermore, the units



	BOX025	BOX030	BOX040	BOX050	BOX063	BOX075	BOX090	BOX110	BOX130	BOX150	STADIO-63	STADIO-71	STADIO-80	STADIO-90
	synthetic oil							mineral oil			synthetic oil			
T°C	-25°C ÷ +50°C							-5°C ÷ +40°C			-25°C ÷ +50°C			
ISO VG...	ISO VG320							ISO VG460			ISO VG320			
oil type	AGIP							BLASIA 460			TELIUM VSF320			
	SHELL							OMALA OIL460			OMALA S4 320			
	MOBIL							MOBILGEAR 634			GLYGOYLE 320			
	CASTROL							ALPHASYN PG320			ALPHASYN PG320			
	BP							ENERGOL GR-XP460			ENERGOL SG-XP320			
oil quantity (lit)	B3	0,02	0,04	0,08	0,15	0,30	0,55	1,00	3	4,5	7	0,16	0,25	0,28
	B6, B7 B8, V5, V6								2,2	3,3	5,1			
maintenance	pre-lubricated by Motive							pre-lubricated with oil for B3 position			pre-lubricated by Motive			
	none, lifetime lubrication							oil change after 400 working hours, than every 4000 working hours			none, lifetime lubrication			

tab. 3

BOX063, BOX075, BOX090, BOX110, BOX130 and BOX150 are accompanied by a breather plug. Before start-up, we suggest to re-place the filler plug in the upper side of the unit with the breather plug. This operation is compulsory on BOX110, 130 and 150.

The combination on the input shaft of 2 taper roller bearings (mounted on size 75 and up to get an high resistance to the axial loads) and 2 nilos (mounted on the unit sizes 75 up to 150 to keep lubricating grease inside the bearings even when they are not touched by the lubrication oil) or, in alternative, special RS shields on such taper bearings, permits the mounting of the whole BOX range, from the size 25 to the size 150, in the positions V5 and V6.

Mounting positions B6 or B7 are also permitted on all the BOX series, thanks

to the adoption of 2RS auto-lubricated bearings on the output shaft.

In conclusion, the whole BOX series can be mounted in any position with no need of specifications in the order.



MOUNTING POSITIONS

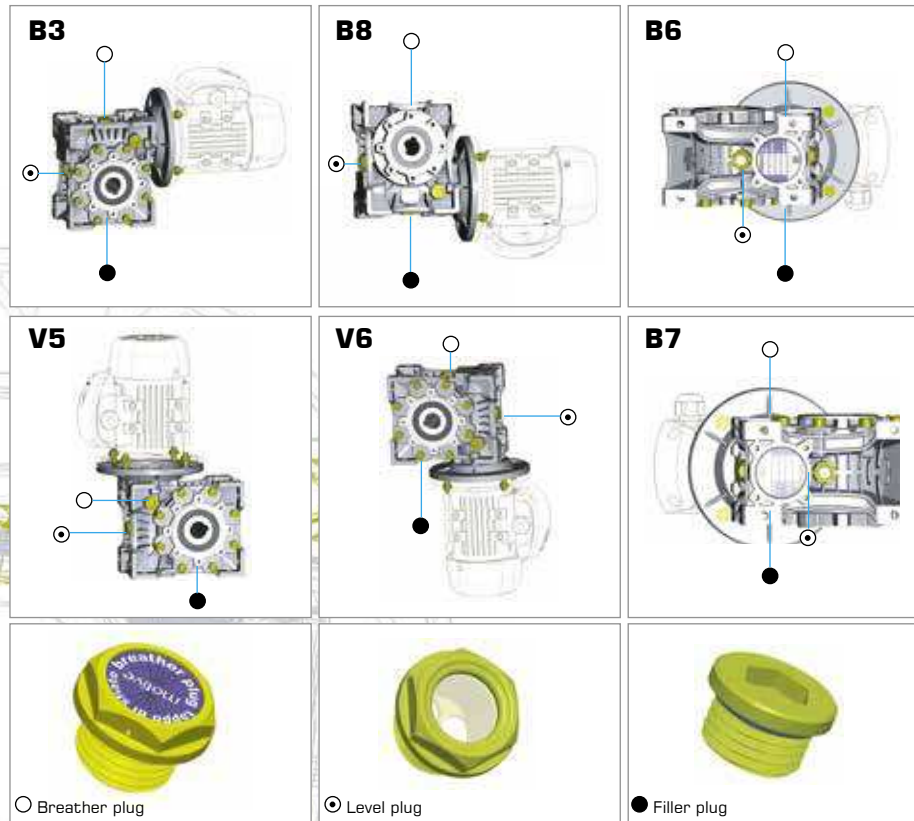
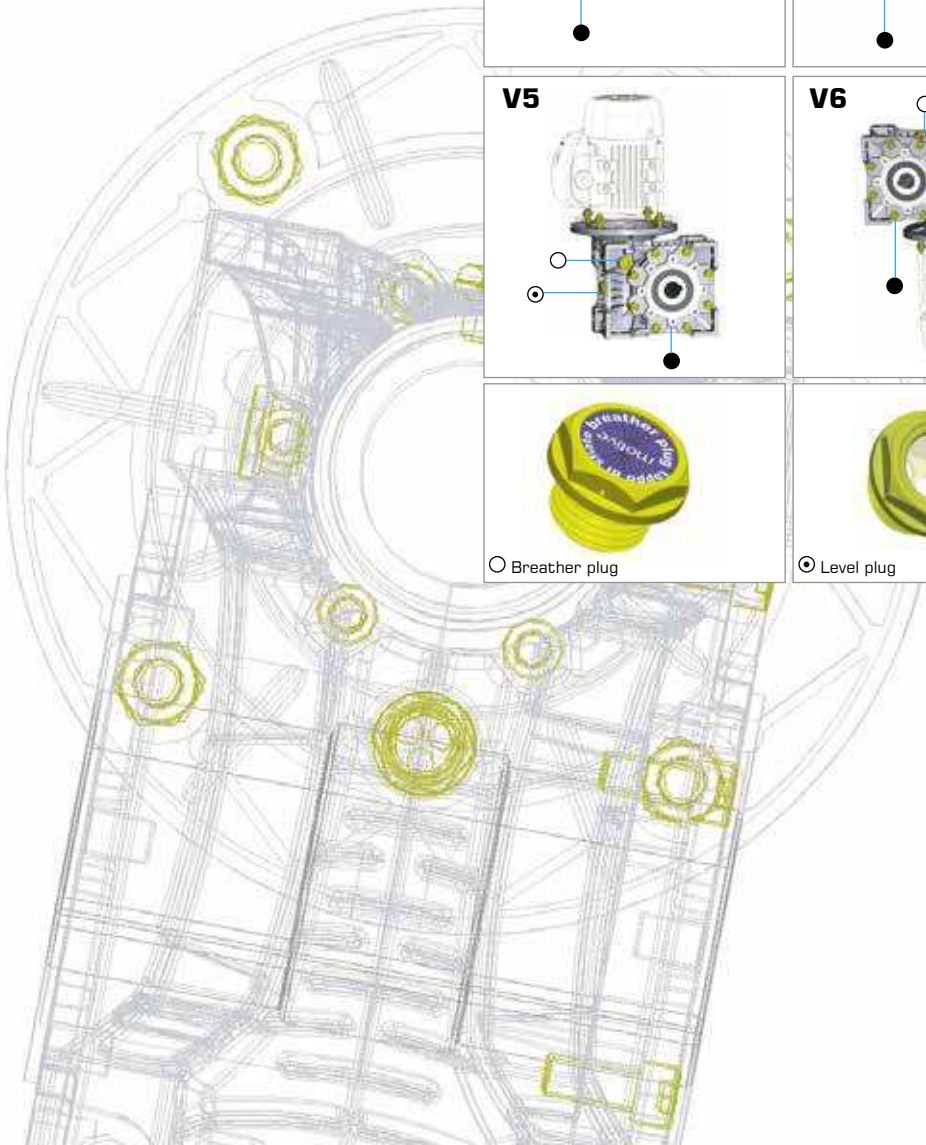

Like all connectable motive motors and gearboxes, STADIO is supplied by Motive with synthetic oil suitable for the whole lifetime. No maintenance requested.

Rated output torque M_{n2} [Nm]

Torque output transmissible under uniform loading and referred to the input speed n_1 and the corresponding output speed n_2 .

The output torque can be calculated with the following formula:

$$M_{n2} = \frac{P_{n1} [kW] \cdot 9550}{n_2} \cdot \eta_d$$

Torque demand M_{r2} [Nm]

Torque calculated based on application requirements. It must be $\leq M_{n2}$ of the chosen BOX unit.

Input power P_{n1} [kW]

This is the power value of the motor applied to the input shaft and corresponding to a certain input speed n_1 , a service factor $f_s=1$ and a duty service S_1 .

It is even possible to calculate the motorsize necessary by using the formula:

$$P_{n1} [kW] = \frac{M_{r2} \cdot n_2}{9550 \cdot \eta_d}$$

Since the value calculated in this way could not really correspond to an input power actually available in the IEC standardised motors, it will be necessary to choose, among the input powers available, the one which is immediately higher, checking this in the Motive catalogue of the motors.

Gear ratio i

It is the relationship of the input speed n_1 and the output speed n_2

$$i = \frac{n_1}{n_2}$$

In the BOX units with pre-stage reduction (BOX+STADIO), the total ratio is given by the PC pre-stage reduction

ratio multiplied by the BOX unit ratio. In the combined BOX units (BOX+BOX), the total ratio is the result of the product of the ratio of the two single boxes composing the combined unit.

Input speed n_1 [rpm]

It is the speed the BOX unit is driven at.

Output speed n_2 [rpm]

It is the rotation speed of the output shaft.

Service factor f_s

It is a numeric value describing the BOX unit service duty. With unavoidable approximation, it takes into consideration:

- the daily working hours **h/d**
- the load classification (see table 2), and then the moment of inertia of the driven masses.
- The number of starts per hour **s/h**
- The presence of brake motors, for which it is necessary to multiply for 1.12 the service factor value deducted by the graph 2.
- The significance of the application in terms of safety, for example lifting of parts
- if the rotation is in 2 senses, the f_{sr} increases by 25%.

In the graph 2, the service factor f_{sr} required by a certain application can be attained, after having selected the proper "daily working hours" (h/d) column, by intersecting the number of starts per hour (s/h) and one of the a, b or c curves. The curves a, b and c are linked with the load classification described in the table 2.

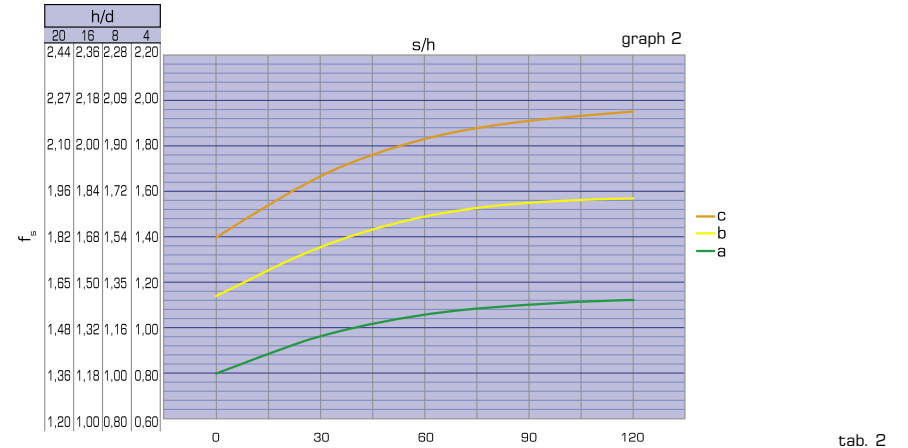

load classification	application
c uneven operation, heavy loads, larger masses to be accelerated	conveyors with violent jerks; compressors and alternate pumps with 1 or more cylinders; machinery for bricks, tiles and clay; kneaders; milling machines; lifting winches with buckets; rotting furnaces; heavy fans or mining purposes; mixers for heavy materials; machine-tools; planing kinds; alternating saws; shears; tumbling barrels; vibrators; shredders; turntables
b starting with moderate loads, uneven operating conditions, medium size masses to be accelerated	belt conveyors with varied load with transfer of bridge trucks for light duty; levelling machines; shakers and mixed for liquid with variable density and viscosity; machines for the food industry (kneading troughs, mincing machines, slicing machines, etc); sifting machines for sand gravel; textile industry machines; cranes, hoists, goodstifts; fertilizer scrapers; concrete mixers; folding machines; winches; crane mechanisms
a easy starting, smooth operation, small masses be accelerated	belt conveyors for light material; centrifugal pumps; rotary gear pumps; screw feeders for light materials; lifts; bottling machines; auxiliary controls of tool machines; fans; power generators; fillers; small mixers

If, after the selection of the right M_{r2} and n_2 in the following performance tables, you don't find a BOX unit whose service factor $f_s \geq$ of the requested one f_{sr} , you can choose a BOX unit in which $M_{n2} > M_{r2}$. In fact, in order to satisfy f_{sr} , you can choose another BOX unit whose output torque is $\geq M_{c2}$ output torque, where: $M_{c2} = M_{r2} \cdot f_{sr}$. Note: This rule is valid only if the new BOX unit that has been selected in this way has a service factor $f_s \geq 1$ in the performance tables. From another point of view, the value of f_s

in the performance tables refers to a case in which the effective torque requested by the application M_{r2} matches perfectly with the one appearing on the catalogue M_{n2} . Whenever the torque indicated in the performance table is higher than the requested one, the offered service factor of the performance table can be increased according to the formula:

$$f_{s \text{ real}} = \frac{f_s \text{ on the table} \cdot M_{n2} \text{ on the table}}{M_{r2}}$$

The value of f_s calculated in this way must be $\geq f_{sr}$.

Configure what you need by this automatic consultant, and get CAD files and data sheets

Motive configurator allows you to shape Motive products, combine them as you want, and finally to download 2D/3D CAD drawings, and a PDF datasheet.

Search by performance

If you're not sure about the best products combination that you should select for your purpose, you can input your wishes, like final torque, final speed, use, etc, and the configurator will act like a consultant.

It will give you a list of applicable product configurations; you can then download a PDF data sheet featuring performance data and dimensional drawings for each configuration, as well as 2D and 3D drawings.

Search by product



To be used if you already know the product configuration that you want, and you just want to get quicker a PDF data sheet featuring performance data and dimensional drawings for 2D and 3D drawings.



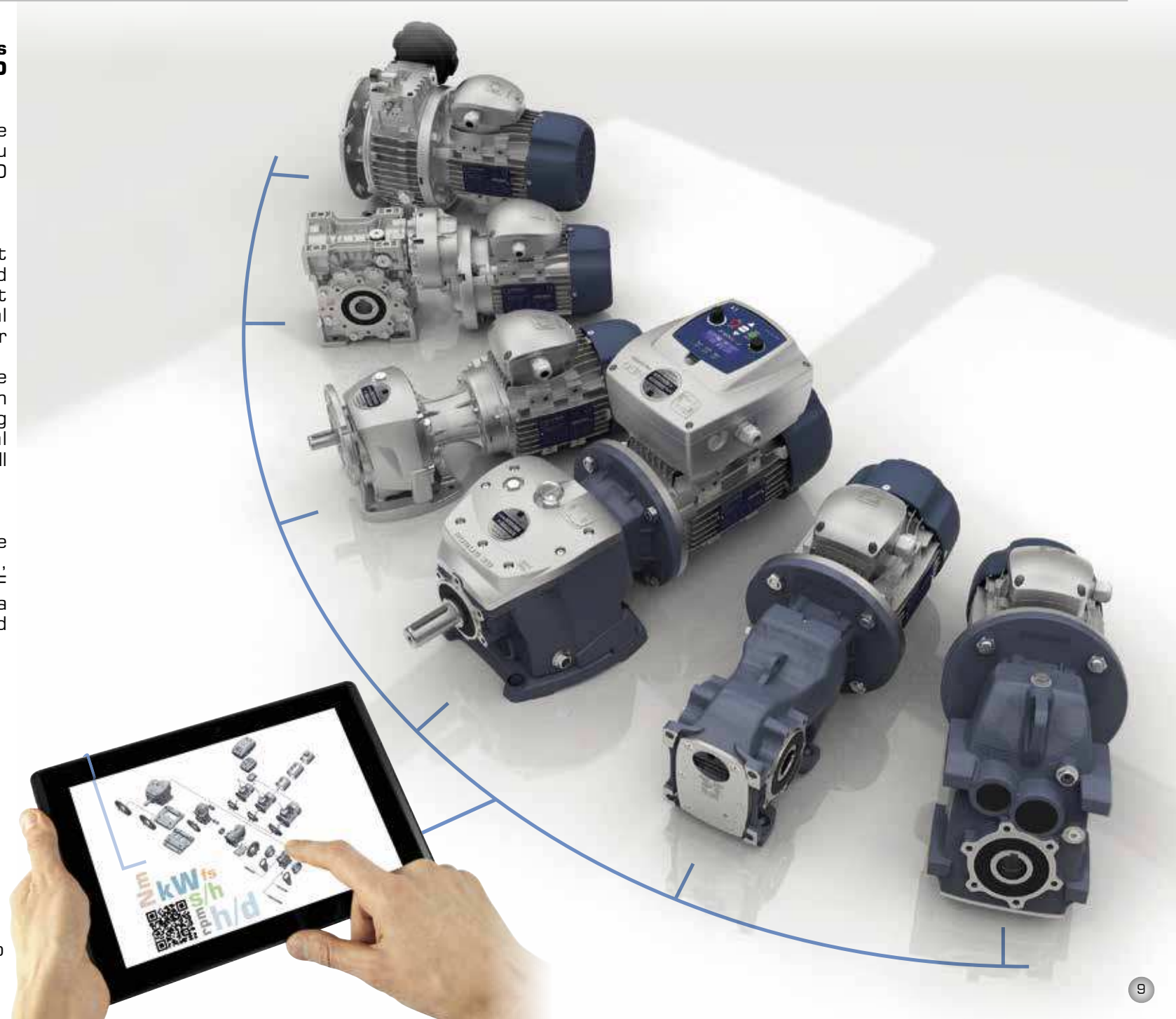



free access without login
<http://www.motive.it/configuratore.php>



BOX PERFORMANCE TABLES

P_1	n_2 [rpm]	M_2 [Nm]	f_s	i			
0,09 kW	186,7	4,0	2,8	7,5	BOX025	56B-4	
	140,0	5,1	2,4	10		56B-4	
	93,3	7,2	1,6	15		56B-4	
	70,0	9,3	1,3	20		56B-4	
	46,7	12,0	1,1	30		56B-4	
	35,0	15,3	0,9	40		56B-4	
	186,7	3,8	4,6	7,5		BOX030	56B-4
	140,0	5,0	3,6	10			56B-4
	93,3	6,7	2,5	15			56B-4
	70,0	6,6	2,0	20			56B-4
	56,0	8,5	2,0	25	56B-4		
	46,7	10,6	1,7	30	56B-4		
	35,0	13,1	1,2	40	56B-4		
	28,0	14,0	1,0	50	56B-4		
	23,3	18,0	0,9	60	56B-4		
	4,7	112,6	0,8	300	BOX030+BOX040		56B-4
	3,5	139,9	1,2	400	BOX030+BOX050	56B-4	
	2,8	151,8	1,0	500		56B-4	
	2,3	172,1	0,9	600		56B-4	
	1,9	177,9	0,8	750		56B-4	
1,6	232,2	0,7	900	56B-4			
1,6	258,7	1,0	900	56B-4			
1,2	342,1	0,9	1200	BOX030+BOX063		56B-4	
0,93	341,6	0,7	1500			56B-4	
0,13 kW	373,3	2,9	3,0	7,5		BOX025	56B-2
	280,0	3,7	2,6	10			56B-2
	186,7	5,2	1,8	15	56B-2		
	186,7	5,5	3,4	7,5	BOX030		63A-4
	140,0	7,2	2,7	10			63A-4
	93,3	9,7	1,9	15			63A-4
	70,0	12,3	1,5	20		63A-4	
	56,0	13,8	1,5	25		63A-4	
	46,7	15,4	1,3	30		63A-4	
	35,0	19,0	0,9	40		63A-4	
	46,7	18,5	2,6	30		BOX040	63A-4
	35,0	22,3	1,9	40			63A-4
	28,0	26,8	1,5	50			63A-4
	23,3	28,8	1,3	60	63A-4		
	23,3	30,8	2,3	60	BOX050		63A-4
	17,5	37,5	1,9	80			63A-4
	14,0	39,9	1,4	100		63A-4	
	4,7	151,6	1,2	300		63A-4	
	3,5	195,5	0,9	400		BOX030+BOX050	63A-4
	2,8	219,3	0,7	500			63A-4
	2,8	241,5	1,3	500	63A-4		
	2,3	276,9	1,1	600	BOX030+BOX063		63A-4
	1,9	278,7	0,9	750			63A-4
	1,6	423,4	1,2	900	BOX040+BOX075		63A-4
	1,2	543,7	0,9	1200			63A-4
	0,8	774,3	0,9	1800	BOX040+BOX090		63A-4
	0,6	910,7	1,7	2400			63A-4
	0,4	1526,0	1,0	4000	BOX050+BOX110		63A-4
	0,5	1183,1	1,2	3000		63A-4	
	0,3	1711,9	0,8	5000		63A-4	

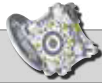
P_1	n_2 [rpm]	M_2 [Nm]	f_s	i			
0,18 kW	373,3	3,8	3,2	7,5	BOX030	63A-2	
	280,0	5,0	2,5	10		63A-2	
	186,7	6,7	1,7	15		63A-2	
	186,7	7,6	2,3	7,5		BOX040	63B-4
	140,0	9,9	1,8	10			63B-4
	140,0	8,5	1,3	20			63A-2
	112,0	9,5	1,4	25			63A-2
	93,3	13,4	1,3	15			63B-4
	70,0	13,1	0,9	40			63A-2
	70,0	17,0	1,0	20			63B-4
	56,0	19,1	1,0	25	63B-4		
	46,7	21,3	0,8	30	63B-4		
	93,3	12,8	2,4	30	BOX050		63A-2
	70,0	18,8	2,0	20		63B-4	
	56,0	22,7	1,7	25		63B-4	
	46,7	25,7	1,7	30		63B-4	
	45,0	29,2	1,5	20		BOX030+BOX063	71A-6
	35,0	30,9	1,3	40			63B-4
	36,0	35,2	1,3	25			71A-6
	30,0	39,9	1,3	30			71A-6
	28,0	37,1	1,0	50			63B-4
	22,5	48,1	1,0	40			71A-6
	35,0	33,5	2,3	40	BOX040+BOX075		63B-4
	28,0	37,6	1,9	50			63B-4
	23,3	42,7	1,6	60			63B-4
	17,5	51,9	1,2	80			63B-4
	18,0	58,5	1,4	50		71A-6	
	14,0	55,3	0,9	100		63B-4	
	15,0	66,4	1,1	60		71A-6	
	11,3	80,7	0,9	80		71A-6	
4,7	217,0	1,1	300	BOX040+BOX090		63B-4	
3,5	279,8	1,0	400			63B-4	
2,8	334,4	0,8	500		BOX050+BOX110	63B-4	
3,5	279,8	0,8	400			63B-4	
2,3	411,6	1,1	600			63B-4	
1,9	454,2	0,9	750			63B-4	
1,6	586,2	0,8	900			63B-4	
1,2	799,8	1,0	1200			63B-4	
0,9	938,4	0,8	1500			63B-4	
0,8	1123,4	1,5	1800			63B-4	
0,6	1372,9	1,1	2400	63B-4			

P_1	n_2 [rpm]	M_2 [Nm]	f_s	i				
0,25 kW	373,3	5,3	2,3	7,5	BOX030	63B-2		
	280,0	6,9	1,8	10		63B-2		
	186,7	9,3	1,3	15		63B-2		
	140,0	11,8	0,9	20		63B-2		
	112,0	13,2	1,0	25		63B-2		
	186,7	11,2	3,6	7,5		BOX040	71A-4	
	140,0	14,5	2,8	10			71A-4	
	120,0	17,4	2,6	7,5			71B-6	
	93,3	20,7	1,9	15			71A-4	
	90,0	22,6	2,0	10			71B-6	
	70,0	26,1	1,5	20	71A-4			
	60,0	32,2	1,4	15	71B-6			
	56,0	31,5	1,2	25	71A-4			
	46,7	35,7	1,3	30	71A-4			
	45,0	40,5	1,1	20	71B-6			
	35,0	43,0	0,9	40	71A-4			
	36,0	48,9	0,9	25	71B-6			
	30,0	55,5	0,9	30	71B-6			
	70,0	27,4	2,7	20	BOX040	71A-4		
	56,0	32,1	2,2	25		71A-4		
	46,7	36,1	2,3	30		71A-4		
	45,0	39,9	1,9	20		71B-6		
	35,0	46,6	1,7	40		71A-4		
	36,0	49,9	1,5	25		71B-6		
	30,0	56,2	1,7	30		BOX050	71B-6	
	28,0	52,3	1,4	50			71A-4	
	23,3	59,2	1,1	60			71A-4	
	22,5	72,5	1,2	40			71B-6	
	18,0	81,3	1,0	50	71B-6			
	15,0	92,2	0,8	60	71B-6			
28,0	57,6	2,4	50	BOX063	71A-4			
23,3	66,0	2,0	60		71A-4			
17,5	79,0	1,6	80		71A-4			
18,0	89,5	1,8	50		71B-6			
14,0	87,1	1,4	100		71A-4			
15,0	102,7	1,5	60		71B-6			
11,3	122,9	1,2	80		71B-6			
9,0	135,6	1,0	100		71B-6			
3,5	439,4	1,1	400		BOX040+BOX075	71A-4		
2,8	511,9	0,8	500			71A-4		
2,3	621,7	1,2	600	71A-4				
1,9	658,7	0,9	750	BOX040+BOX090		71A-4		
1,6	865,2	0,8	900			71A-4		
1,2	1181,6	1,3	1200			71A-4		
0,9	1318,2	1,2	1500			BOX050+BOX110	71A-4	
0,8	1554,2	1,1	1800				71A-4	
0,6	1624,0	1,0	2400				BOX063+BOX130	71A-4
0,5	1548,0	1,0	3000					71A-4

BOX PERFORMANCE TABLES

P ₁	n ₂ [rpm]	M ₂ [Nm]	f _s	i		
					Model	Output
0,37 kW	373,3	8,3	3,3	7,5	BOX040	71A-2
	280,0	10,8	2,6	10		71A-2
	186,7	15,3	1,9	15		71A-2
	186,7	16,5	2,4	7,5		71B-4
	140,0	21,5	1,9	10		71B-4
	140,0	19,3	1,4	20		71A-2
	112,0	23,3	1,1	25		71A-2
	93,3	30,7	1,3	15		71B-4
	70,0	38,6	1,0	20		71B-4
	56,0	46,6	0,8	25		71B-4
	46,7	52,8	0,8	30	71B-4	
	140,0	22,1	3,3	10	BOX050	71B-4
	112,0	23,7	2,0	25		71A-2
	120,0	26,2	3,3	7,5		80A-6
	93,3	31,0	2,4	15		71B-4
	90,0	34,4	2,5	10		80A-6
	70,0	40,5	1,8	20		71B-4
	60,0	48,2	1,8	15		80A-6
	56,0	47,4	1,5	25		71B-4
	46,7	53,5	1,5	30		71B-4
	45,0	63,0	1,3	20		80A-6
	35,0	69,0	1,1	40	71B-4	
	36,0	71,2	1,0	25	80A-6	
	30,0	83,2	1,1	30	80A-6	
	28,0	77,4	0,9	50	71B-4	
	45,0	64,2	2,4	20	80A-6	
	35,0	71,3	2,1	40	71B-4	
	36,0	78,2	1,9	25	80A-6	
	30,0	85,2	2,1	30	80A-6	
	28,0	85,2	1,6	50	71B-4	
	23,3	97,7	1,4	60	71B-4	
	22,5	110,9	1,6	40	80A-6	
	17,5	116,9	1,1	80	71B-4	
	18,0	132,5	1,2	50	80A-6	
	14,0	129,0	0,9	100	71B-4	
	15,0	151,9	1,0	60	80A-6	
	18,0	138,8	1,8	50	80A-6	
	15,0	154,3	1,5	60	80A-6	
	11,3	185,3	1,2	80	80A-6	
	9,0	221,8	1,0	100	80A-6	
	4,7	489,5	1,0	300	71B-4	
	3,5	635,5	0,7	400	71B-4	
	4,7	521,8	1,5	300	71B-4	
	3,5	637,2	1,2	400	71B-4	
	2,8	786,8	0,9	500	71B-4	
	2,3	898,9	0,8	600	71B-4	
	1,9	1061,4	1,3	750	71B-4	
	1,6	1642,5	1,2	900	71B-4	
	1,2	1748,8	0,8	1200	71B-4	
	0,9	1674,0	1,0	1500	71B-4	
	0,8	1698,0	1,0	1800	71B-4	

P ₁	n ₂ [rpm]	M ₂ [Nm]	f _s	i		
					Model	Output
0,55 kW	373,3	12,3	2,2	7,5	BOX040	71B-2
	280,0	16,0	1,8	10		71B-2
	112,0	34,6	0,8	25		71B-2
	186,7	25,0	2,9	7,5		80A-4
	140,0	30,1	1,7	20		71B-2
	140,0	32,8	2,2	10		80A-4
	112,0	35,3	1,4	25		71B-2
	120,0	39,0	2,2	7,5		80B-6
	93,3	46,0	1,6	15		80A-4
	90,0	51,1	1,7	10		80B-6
	70,0	60,2	1,2	20	80A-4	
	60,0	71,6	1,2	15	80B-6	
	56,0	70,5	1,0	25	80A-4	
	46,7	65,2	0,7	60	71B-2	
	46,7	79,5	1,0	30	80A-4	
	45,0	93,6	0,9	20	80B-6	
	70,0	61,4	2,2	20	80A-4	
	60,0	72,1	2,2	15	80B-6	
	56,0	74,8	1,8	25	80A-4	
	46,7	81,4	1,9	30	80A-4	
	45,0	95,5	1,6	20	80B-6	
	35,0	106,0	1,4	40	80A-4	
	36,0	116,3	1,3	25	80B-6	
	30,0	126,6	1,4	30	80B-6	
	28,0	126,6	1,1	50	80A-4	
	23,3	145,2	0,9	60	80A-4	
	22,5	164,8	1,1	40	80B-6	
	35,0	110,8	2,0	40	80A-4	
	30,0	132,7	2,0	30	80B-6	
	28,0	132,6	1,6	50	80A-4	
	23,3	147,4	1,4	60	80A-4	
	22,5	172,3	1,5	40	80B-6	
	17,5	177,1	1,1	80	80A-4	
	18,0	206,3	1,2	50	80B-6	
	15,0	229,4	1,0	60	80B-6	
	17,5	184,3	1,5	80	80A-4	
	18,0	213,3	2,0	50	80B-6	
	14,0	221,4	1,2	100	80A-4	
	15,0	243,7	1,6	60	80B-6	
	11,3	286,7	1,1	80	80B-6	
	9,0	344,3	0,9	100	80B-6	
	17,5	195,1	2,6	80	80A-4	
	14,0	234,9	2,0	100	80A-4	
	11,3	303,5	1,9	80	80B-6	
	9,0	365,3	1,5	100	80B-6	
	4,7	797,7	2,0	300	80A-4	
	3,5	1013,7	1,4	400	80A-4	
	2,8	1198,1	1,1	500	80A-4	
	2,3	1390,5	1,0	600	80A-4	
	1,9	1567,6	0,9	750	80A-4	
	1,2	1705,0	1,0	1200	80A-4	

P ₁	n ₂ [rpm]	M ₂ [Nm]	f _s	i		
					Model	Output
0,75 kW	373,3	17,1	3,0	7,5	BOX050	80A-2
	280,0	22,4	2,4	10		80A-2
	186,7	34,1	2,1	7,5		80B-4
	140,0	44,8	1,6	10		80B-4
	112,0	48,1	1,0	25		80A-2
	93,3	62,8	1,2	15		80B-4
	70,0	82,1	0,9	20		80B-4
	112,0	51,0	1,8	25		80A-2
	120,0	53,2	2,9	7,5		90S-6
	93,3	63,2	2,2	15		80B-4
	90,0	70,5	2,3	10	90S-6	
	70,0	83,7	1,6	20	80B-4	
	60,0	98,4	1,6	15	90S-6	
	56,0	101,9	1,3	25	80B-4	
	46,7	111,0	1,4	30	80B-4	
	45,0	130,2	1,2	20	90S-6	
	35,0	144,5	1,0	40	80B-4	
	36,0	158,6	0,9	25	90S-6	
	30,0	172,6	1,0	30	90S-6	
	60,0	101,7	2,4	15	90S-6	
	56,0	104,8	2,0	25	80B-4	
	46,7	116,3	2,0	30	80B-4	
	45,0	132,9	1,9	20	90S-6	
	35,0	151,0	1,5	40	80B-4	
	36,0	162,9	1,4	25	90S-6	
	30,0	181,0	1,5	30	90S-6	
	28,0	180,9	1,2	50	80B-4	
	23,3	201,1	1,0	60	80B-4	
	22,5	234,9	1,1	40	90S-6	
	30,0	192,9	2,6	30	90S-6	
	28,0	187,0	1,8	50	80B-4	
	23,3	213,6	1,5	60	80B-4	
	22,5	235,6	1,8	40	90S-6	
	17,5	251,3	1,1	80	80B-4	
	18,0	290,9	1,4	50	90S-6	
	14,0	301,8	0,9	100	80B-4	
	15,0	332,3	1,1	60	90S-6	
	17,5	266,0	1,9	80	80B-4	
	14,0	320,3	1,5	100	80B-4	
	15,0	337,1	2,1	60	90S-6	
	11,3	413,8	1,4	80	90S-6	
	9,0	498,2	1,1	100	90S-6	
	4,67	1087,7	1,5	300	80B-4	
	3,50	1378,7	1,1	400	80B-4	
	2,30	1631	1,0	600	80B-4	
	1,90	1804	1,0	750	80B-4	
	1,60	1826	1,0	900	80B-4	

BOX PERFORMANCE TABLES

P ₁	n ₂ [rpm]	M ₂ [Nm]	f _s	i		
					Model	Input
1,1 kW	373,3	25,0	2,1	7,5	BOX050	80B-2
	280,0	32,8	1,6	10		80B-2
	186,7	46,0	1,2	15		80B-2
	186,7	46,4	2,1	15		80B-2
	186,7	50,1	2,6	7,5		90S-4
	140,0	66,5	2,0	10	90S-4	
	120,0	78,0	2,0	7,5	90L-6	
	112,0	74,8	1,2	25	80B-2	
	93,3	92,7	1,5	15	90S-4	
	90,0	103,4	1,5	10	90L-6	
	70,0	122,8	1,1	20	90S-4	
	60,0	144,3	1,1	15	90L-6	
	56,0	149,5	0,9	25	90S-4	
	46,7	162,8	1,0	30	90S-4	
	45,0	191,0	0,8	20	90L-6	
	112,0	76,8	1,9	25	BOX063	80B-2
	93,3	95,9	2,1	15		90S-4
	90,0	104,6	2,3	10		90L-6
	70,0	125,3	1,7	20		90S-4
	60,0	149,2	1,6	15		90L-6
	56,0	153,6	1,3	25	90S-4	
	46,7	170,6	1,3	30	90S-4	
	45,0	194,9	1,3	20	90L-6	
	35,0	221,5	1,0	40	90S-4	
	36,0	239,0	1,0	25	90L-6	
	30,0	265,4	1,0	30	90L-6	
	35,0	222,1	1,6	40	90S-4	
	36,0	243,7	1,6	25	90L-6	
	30,0	282,9	1,8	30	90L-6	
	28,0	274,3	1,3	50	90S-4	
	23,3	313,3	1,0	60	90S-4	
	22,5	345,5	1,2	40	90L-6	
	18,0	426,6	1,0	50	90L-6	
	15,0	430,0	0,8	60	90L-6	
	28,0	275,8	2,3	50	90S-4	
	23,3	317,9	1,9	60	90S-4	
	22,5	360,4	2,3	40	90L-6	
	17,5	390,2	1,3	80	90S-4	
	18,0	429,0	1,8	50	90L-6	
	14,0	469,7	1,0	100	90S-4	
	15,0	494,4	1,4	60	90L-6	
	11,3	607,0	1,0	80	90L-6	
	17,5	390,2	2,1	80	90S-4	
	14,0	465,2	1,5	100	90S-4	
	11,3	607,0	1,4	80	90L-6	
9,0	723,7	1,1	100	90L-6		
4,7	1312	1,2	300	90S-4		
3,5	1519	1,0	400	90S-4		
2,8	1629	1,0	500	BOX063+BOX130	90S-4	

P ₁	n ₂ [rpm]	M ₂ [Nm]	f _s	i		
					Model	Input
1,5 kW	373,3	34,2	2,7	7,5	BOX063	90S-2
	280,0	45,3	2,1	10		90S-2
	186,7	68,4	1,9	7,5		90L-4
	140,0	83,7	1,2	20		90S-2
	140,0	90,7	1,5	10		90L-4
	112,0	101,9	0,9	25	90S-2	
	93,3	126,5	1,1	15	90L-4	
	70,0	167,4	0,8	20	90L-4	
	280,0	45,8	3,1	10	BOX075	90S-2
	186,7	65,4	2,2	15		90L-4
	140,0	91,7	2,2	10		90L-4
	120,0	108,6	2,0	7,5		100LA-6
	112,0	104,8	1,4	25		90S-2
	93,3	130,8	1,5	15	90L-4	
	90,0	142,6	1,7	10	100LA-6	
	70,0	170,9	1,3	20	90L-4	
	60,0	203,4	1,2	15	100LA-6	
	56,0	209,5	1,0	25	90L-4	
	46,7	232,7	1,0	30	90L-4	
	90,0	143,1	2,7	10	100LA-6	
	70,0	172,1	2,1	20	90L-4	
	60,0	210,6	2,1	15	100LA-6	
	56,0	213,6	1,6	25	90L-4	
	46,7	248,0	1,7	30	90L-4	
	45,0	267,7	1,5	20	BOX090	100LA-6
	35,0	302,9	1,2	40		90L-4
	36,0	332,3	1,2	25		100LA-6
	30,0	385,8	1,3	30		100LA-6
	28,0	374,0	0,9	50		90L-4
	23,3	427,3	0,8	60	90L-4	
	45,0	274,1	2,7	20	100LA-6	
	35,0	316,0	2,2	40	90L-4	
	36,0	333,5	2,4	25	100LA-6	
	30,0	386,8	2,3	30	100LA-6	
	28,0	376,0	1,7	50	90L-4	
	23,3	433,4	1,4	60	90L-4	
	22,5	491,5	1,7	40	100LA-6	
	17,5	532,1	0,9	80	90L-4	
	18,0	584,9	1,3	50	100LA-6	
	15,0	674,2	1,1	60	100LA-6	
	22,5	477,5	2,3	40	100LA-6	
	18,0	573,0	1,8	50	100LA-6	
	17,5	532,1	1,5	80	90L-4	
	15,0	668,5	1,4	60	100LA-6	
	14,0	634,4	1,1	100	90L-4	
11,3	827,7	1,1	80	100LA-6		
4,7	1789,0	1,0	300	BOX063+BOX130	90L-4	

P ₁	n ₂ [rpm]	M ₂ [Nm]	f _s	i			
					Model	Input	
2,2 kW	373,3	50,1	1,8	7,5	BOX063	90L-2	
	280,0	66,5	1,5	10		90L-2	
	186,7	92,7	1,1	15		90L-2	
	373,3	51,2	2,5	7,5		BOX075	90L-2
	280,0	67,2	2,1	10			90L-2
	186,7	95,9	1,5	15	90L-2		
	186,7	102,4	1,8	7,5	100LA-4		
	140,0	125,3	1,3	20	90L-2		
	140,0	134,5	1,5	10	100LA-4		
	112,0	153,6	1,0	25	90L-2		
	93,3	191,8	1,0	15	100LA-4		
	186,7	102,8	2,9	7,5	100LA-4		
	140,0	126,2	2,0	20	90L-2		
	140,0	134,9	2,3	10	100LA-4		
	120,0	159,9	2,2	7,5	112M-6		
	112,0	156,6	1,6	25	90L-2		
	93,3	198,5	1,9	15	100LA-4		
	90,0	209,9	1,8	10	112M-6		
	70,0	252,4	1,4	20	100LA-4		
	60,0	308,8	1,4	15	112M-6		
	56,0	313,3	1,2	25	100LA-4		
	46,7	363,8	1,0	30	100LA-4		
	45,0	392,7	1,0	20	112M-6		
	112,0	157,2	3,1	25	90L-2		
	90,0	212,9	3,5	10	112M-6		
	70,0	258,4	2,5	20	100LA-4		
	60,0	309,5	2,6	15	112M-6		
	56,0	314,4	2,2	25	100LA-4		
	46,7	364,7	2,0	30	100LA-4		
	45,0	402,0	1,9	20	112M-6		
	35,0	463,4	1,5	40	100LA-4		
	36,0	489,1	1,6	25	112M-6		
	30,0	567,3	1,6	30	112M-6		
	28,0	551,5	1,2	50	100LA-4		
	23,3	635,7	1,0	60	100LA-4		
	36,0	472,7	2,2	25	112M-6		
	35,0	450,2	2,2	40	100LA-4		
	30,0	553,3	2,1	30	112M-6		
	28,0	540,3	1,7	50	100LA-4		
	23,3	630,3	1,4	60	100LA-4		
	22,5	700,3	1,6	40	112M-6		
	18,0	840,4	1,2	50	112M-6		
	17,5	780,4	1,0	80	100LA-4		
	15,0	980,5	1,0	60	112M-6		
	28,0	540,3	2,5	50	100LA-4		
23,3	630,3	1,9	60	100LA-4			
17,5	780,4	1,4	80	100LA-4			
14,0	930,4	1,0	100	100LA-4			

BOX PERFORMANCE TABLES

P ₁	n ₂ [rpm]	M ₂ [Nm]	f _s	i		
					Model	Part No.
3 kW	373,3	69,8	1,9	7,5	BOX075	100L-2
	280,0	91,7	1,6	10		100L-2
	186,7	139,7	1,4	7,5		100LB-4
	140,0	183,4	1,1	10		100LB-4
	93,3	261,5	0,8	15	100LB-4	
	373,3	70,1	3,0	7,5	BOX090	100L-2
	280,0	92,0	2,6	10		100L-2
	186,7	140,1	2,1	7,5		100LB-4
	140,0	184,0	1,7	10		100LB-4
	93,3	270,7	1,4	15		100LB-4
	70,0	344,2	1,0	20		100LB-4
	56,0	427,2	0,8	25		100LB-4
	46,7	496,1	0,9	30		100LB-4
	120,0	220,6	3,1	7,5		132S-6
	93,3	271,4	2,5	15		100LB-4
	90,0	290,3	2,5	10		132S-6
	70,0	352,4	1,9	20		100LB-4
	60,0	422,1	1,9	15	132S-6	
	56,0	428,7	1,6	25	100LB-4	
	46,7	497,3	1,5	30	100LB-4	
	45,0	548,2	1,4	20	132S-6	
	35,0	631,9	1,1	40	100LB-4	
	28,0	752,1	0,9	50	100LB-4	
	90,0	273,8	3,4	10	132S-6	
	60,0	401,1	2,6	15	132S-6	
	56,0	414,4	2,2	25	100LB-4	
	46,7	485,0	2,1	30	100LB-4	
	45,0	528,4	1,9	20	132S-6	
	36,0	644,6	1,6	25	132S-6	
	35,0	613,9	1,6	40	100LB-4	
	30,0	754,5	1,6	30	132S-6	
	28,0	736,7	1,3	50	100LB-4	
	23,3	859,5	1,0	60	100LB-4	
	22,5	955,0	1,2	40	132S-6	
	17,5	1064,1	0,8	80	100LB-4	
	28,0	736,7	1,8	50	100LB-4	
	23,3	859,5	1,4	60	100LB-4	
	17,5	1064,1	1,0	80	100LB-4	
	14,0	1268,8	0,8	100	100LB-4	

P ₁	n ₂ [rpm]	M ₂ [Nm]	f _s	i		
					Model	Part No.
4 kW	373,3	93,1	1,4	7,5	BOX075	112M-2
	280,0	122,2	1,2	10		112M-2
	186,7	186,2	1,0	7,5		112M-4
	140,0	244,5	0,8	10		112M-4
	373,3	93,4	2,2	7,5	BOX090	112M-2
	280,0	122,6	1,9	10		112M-2
	186,7	186,8	1,6	7,5		112M-4
	140,0	245,3	1,3	10		112M-4
	93,3	361,0	1,0	15		112M-4
	70,0	458,9	0,8	20		112M-4
	140,0	248,8	2,5	10		112M-4
	120,0	294,1	2,3	7,5		132M-6
	93,3	361,8	1,9	15		112M-4
	90,0	387,1	1,9	10		132M-6
	70,0	469,9	1,4	20		112M-4
	60,0	562,8	1,4	15		132M-6
	56,0	571,6	1,2	25	112M-4	
	46,7	663,0	1,1	30	112M-4	
	120,0	286,5	3,1	7,5	132M-6	
	90,0	365,0	2,6	10	132M-6	
	60,0	534,8	2,0	15	132M-6	
	56,0	552,5	1,6	25	112M-4	
	46,7	646,7	1,6	30	112M-4	
	45,0	704,6	1,5	20	132M-6	
	36,0	859,5	1,2	25	132M-6	
	35,0	818,6	1,2	40	112M-4	
	28,0	982,3	1,0	50	112M-4	
	23,3	1146,0	0,8	60	112M-4	
	28,0	982,3	1,4	50	112M-4	
	23,3	1146,0	1,1	60	112M-4	
	17,5	1418,9	0,8	80	112M-4	
	186,7	260,0	2,2	7,5	BOX110	132S-4
	140,0	342,2	1,8	10		132S-4
	93,3	497,5	1,4	15		132S-4
	70,0	646,1	1,0	20		132S-4
	140,0	322,7	2,5	10		132S-4
	93,3	472,7	1,9	15		132S-4
	70,0	622,8	1,4	20		132S-4
	56,0	759,7	1,2	25		132S-4
	46,7	889,2	1,2	30		132S-4
35,0	1125,5	0,9	40	132S-4		
70,0	622,8	2,0	20	132S-4		
56,0	759,7	1,5	25	132S-4		
46,7	889,2	1,3	30	132S-4		
35,0	1125,5	1,3	40	132S-4		
28,0	1350,6	1,0	50	132S-4		
23,3	1575,8	0,8	60	132S-4		

P ₁	n ₂ [rpm]	M ₂ [Nm]	f _s	i			
					Model	Part No.	
7,5 kW	186,7	434,9	1,6	7,5	BOX110	132M-4	
	140,0	466,6	1,3	10		132M-4	
	93,3	678,4	1,0	15		132M-4	
	186,7	345,3	2,1	7,5		132M-4	
	140,0	440,0	1,8	10	BOX130	132M-4	
	93,3	644,6	1,4	15		132M-4	
	70,0	849,3	1,0	20		132M-4	
	56,0	1036,0	0,9	25		132M-4	
	46,7	1212,5	0,8	30		132M-4	
	35,0	1534,8	0,7	40		132M-4	
	70,0	849,3	1,5	20		BOX150	132M-4
	56,0	1036,0	1,1	25			132M-4
	46,7	1212,5	0,9	30	132M-4		
	35,0	1534,8	1,0	40	132M-4		
	9,2 kW	186,7	434,9	1,3	7,5	BOX110	132MB-4
		186,7	423,6	1,8	7,5	BOX130	132MB-4
140,0		539,7	1,5	10	132MB-4		
93,3		790,7	1,1	15	132MB-4		
70,0		1041,8	0,8	20	132MB-4		
56,0		1270,8	0,7	25	132MB-4		
70,0		1041,8	1,2	20	BOX150	132MB-4	
56,0		1270,8	0,9	25		132MB-4	
46,7		1487,3	0,8	30		132MB-4	
35,0		1882,7	0,8	40		132MB-4	
11 kW	186,7	506,5	2,3	7,5	BOX150	160M-4	
	140,0	645,3	1,8	10		160M-4	
	93,3	945,5	1,3	15		160M-4	
	70,0	1245,6	1,0	20		160M-4	
	56,0	1519,5	0,8	25		160M-4	
15 kW	186,7	698,0	1,7	7,5	BOX150	160L-4	
	140,0	921,0	1,3	10		160L-4	
	93,3	1351,0	0,9	15		160L-4	
70,0	1760,0	0,7	20	160L-4			

Design features

STADIO construction is modular and therefore it can be supplied as a separate unit to be mounted on any type of fitted geared motor (PAM).

It is not requested any part pre-mounting on the motor shaft.

Like all connectable motive motors and gearboxes, STADIO is supplied by Motive with synthetic oil suitable for the whole lifetime. No maintenance requested.

Like all connectable gearboxes and motors manufactured by Motive, the whole STADIO range can be mounted in any position with no need of specifications in the order

The efficiency at rated speed is 98%. The starting efficiency is always less than the efficiency at rated speed.

The pre-stage unit cannot be used by itself, but only coupled with another reduction unit.

A powder paint coat cancels the negative effects of the aluminium porosity and protects the housing from oxidation.

In order to increase silence, efficiency and duration, gears are made in case hardened (HRC59-63) tempered steel 20CrMnTi (UNI7846) accurately ground on the involute.

Performance

BOX+STADIO		FORMULA	
final ratio	$i:$	=	BOX $i:$ x STADIO $i:$
final service factor	sf	=	BOX sf / 2
final output speed	n_2 [rpm]	=	BOX n_2 / STADIO $i:$
final output torque	M_2 [Nm]	=	BOX M_2 x STADIO $i:$ x 98%
final efficiency	hd [%]	=	BOX η_d x 98%



BOX+STADIO PERFORMANCE TABLES

Some examples:

P ₁ [kW]		i:	n ₂ [rpm]	M ₂ [Nm]	f _s	
0,13	BOX040	i:50 + STADIO-63 + 63A-4	147	9,6	72	0,8
0,13	BOX040	i:40 + STADIO-63 + 63A-4	117	11,9	60	1,0
0,13	BOX040	i:30 + STADIO-63 + 63A-4	88	15,9	49	1,3
0,13	BOX050	i:80 + STADIO-63 + 63A-4	234	6,0	100	1,0
0,13	BOX050	i:60 + STADIO-63 + 63A-4	176	8,0	83	1,2
0,18	BOX040	i:25 + STADIO-63 + 63B-4	73	19,1	63	0,8
0,18	BOX040	i:30 + STADIO-63 + 63B-4	88	15,9	68	0,8
0,18	BOX040	i:25 + STADIO-63 + 63B-4	73	19,1	66	0,9
0,18	BOX040	i:30 + STADIO-63 + 63B-4	88	15,9	75	0,9
0,18	BOX040	i:40 + STADIO-63 + 63A-2	117	23,9	52	0,9
0,18	BOX040	i:20 + STADIO-63 + 63A-4	59	23,9	55	1,0
0,18	BOX040	i:30 + STADIO-63 + 63A-2	88	31,8	40	1,2
0,18	BOX050	i:60 + STADIO-63 + 63B-4	176	8,0	110	0,7
0,18	BOX050	i:80 + STADIO-63 + 63A-2	234	11,9	86	0,8
0,18	BOX050	i:60 + STADIO-63 + 63B-4	176	8,0	123	0,8
0,18	BOX050	i:50 + STADIO-63 + 63B-4	147	9,6	99	0,9
0,18	BOX050	i:50 + STADIO-63 + 63B-4	147	9,6	112	1,0
0,18	BOX050	i:60 + STADIO-63 + 63A-2	176	15,9	69	1,1
0,18	BOX050	i:40 + STADIO-63 + 63B-4	117	11,9	95	1,2
0,18	BOX063	i:100 + STADIO-63 + 63B-4	293	4,8	151	0,8
0,18	BOX063	i:80 + STADIO-63 + 63B-4	234	6,0	136	1,0
0,18	BOX040	i:20 + STADIO-71 + 71A-6	59	15,3	84	0,8
0,25	BOX050	i:40 + STADIO-63 + 63C-4	117	11,9	118	0,9
0,25	BOX050	i:25 + STADIO-63 + 63C-4	73	19,1	87	1,1
0,25	BOX050	i:30 + STADIO-63 + 63C-4	88	15,9	118	1,1
0,25	BOX063	i:60 + STADIO-63 + 63C-4	176	8,0	159	1,0
0,25	BOX063	i:50 + STADIO-63 + 63C-4	147	9,6	140	1,3
0,25	BOX063	i:40 + STADIO-63 + 63C-4	117	11,9	122	1,5
0,25	BOX040	i:20 + STADIO-71 + 71A-4	59	23,8	78	0,8
0,25	BOX050	i:25 + STADIO-71 + 71B-6	74	12,2	138	0,8
0,25	BOX050	i:40 + STADIO-71 + 71A-4	118	11,9	118	0,8
0,25	BOX050	i:30 + STADIO-71 + 71B-6	88	10,2	156	0,9
0,25	BOX050	i:40 + STADIO-71 + 71A-4	118	11,9	133	0,9
0,25	BOX050	i:20 + STADIO-71 + 71B-6	59	15,3	115	1,0
0,25	BOX050	i:25 + STADIO-71 + 71A-4	74	19,0	86	1,0
0,25	BOX050	i:25 + STADIO-71 + 71A-4	74	19,0	92	1,1
0,25	BOX050	i:30 + STADIO-71 + 71A-4	88	15,9	96	1,1
0,25	BOX050	i:30 + STADIO-71 + 71A-4	88	15,9	107	1,2
0,25	BOX050	i:20 + STADIO-71 + 71A-4	59	23,8	78	1,4
0,25	BOX063	i:80 + STADIO-71 + 71A-4	235	6,0	188	0,7
0,25	BOX063	i:60 + STADIO-71 + 71B-6	176	5,1	265	0,8
0,25	BOX063	i:80 + STADIO-71 + 71A-4	235	6,0	225	0,8
0,25	BOX063	i:50 + STADIO-71 + 71B-6	147	6,1	233	0,9
0,25	BOX063	i:60 + STADIO-71 + 71A-4	176	7,9	182	1,0
0,25	BOX063	i:60 + STADIO-71 + 71A-4	176	7,9	159	1,0
0,25	BOX063	i:50 + STADIO-71 + 71A-4	147	9,5	161	1,2
0,25	BOX063	i:25 + STADIO-71 + 71A-4	74	19,0	89	1,8
0,25	BOX075	i:100 + STADIO-71 + 71A-4	294	4,8	225	0,9
0,25	BOX075	i:80 + STADIO-71 + 71A-4	235	6,0	196	1,1

P ₁ [kW]		i:	n ₂ [rpm]	M ₂ [Nm]	f _s	
0,37	BOX050	i:25 + STADIO-71 + 71B-4	74	19,0	138	0,8
0,37	BOX050	i:30 + STADIO-71 + 71B-4	88	15,9	158	0,8
0,37	BOX050	i:40 + STADIO-71 + 71A-2	118	23,8	107	0,8
0,37	BOX050	i:20 + STADIO-71 + 71B-4	59	23,8	115	0,9
0,37	BOX050	i:25 + STADIO-71 + 71A-2	74	38,1	72	1,0
0,37	BOX050	i:30 + STADIO-71 + 71A-2	88	31,7	84	1,1
0,37	BOX063	i:50 + STADIO-71 + 71B-4	147	9,5	239	0,8
0,37	BOX063	i:50 + STADIO-71 + 71B-4	147	9,5	207	0,8
0,37	BOX063	i:40 + STADIO-71 + 71B-4	118	11,9	181	1,0
0,37	BOX063	i:40 + STADIO-71 + 71B-4	118	11,9	205	1,1
0,37	BOX075	i:60 + STADIO-71 + 71B-4	176	7,9	248	0,9
0,37	BOX075	i:50 + STADIO-71 + 71B-4	147	9,5	218	1,1
0,37	BOX090	i:100 + STADIO-71 + 71B-4	294	4,8	362	0,9
0,37	BOX090	i:80 + STADIO-71 + 71B-4	235	6,0	314	1,1
0,37	BOX063	i:40 + STADIO-80 + 80A-6	120	7,5	300	0,8
0,37	BOX063	i:25 + STADIO-80 + 80A-6	75	12,0	218	1,0
0,37	BOX063	i:30 + STADIO-80 + 80A-6	90	10,0	241	1,1
0,37	BOX063	i:20 + STADIO-80 + 80A-6	60	15,0	176	1,2
0,37	BOX075	i:60 + STADIO-80 + 80A-6	180	5,0	423	0,8
0,37	BOX075	i:50 + STADIO-80 + 80A-6	150	6,0	370	0,9
0,55	BOX050	i:30 + STADIO-71 + 71B-2	88	31,7	124	0,8
0,55	BOX050	i:20 + STADIO-71 + 71B-2	59	47,6	89	0,9
0,55	BOX063	i:50 + STADIO-71 + 71B-2	147	19,0	193	0,8
0,55	BOX063	i:30 + STADIO-71 + 71C-4	88	15,9	214	0,9
0,55	BOX063	i:40 + STADIO-71 + 71B-2	118	23,8	161	1,0
0,55	BOX075	i:40 + STADIO-71 + 71C-4	118	11,9	277	1,0
0,55	BOX075	i:25 + STADIO-71 + 71C-4	74	19,0	200	1,2
0,55	BOX075	i:30 + STADIO-71 + 71C-4	88	15,9	225	1,3
0,55	BOX090	i:60 + STADIO-71 + 71C-4	176	7,9	389	1,0
0,55	BOX090	i:50 + STADIO-71 + 71C-4	147	9,5	347	1,3
0,55	BOX090	i:40 + STADIO-71 + 71C-4	118	11,9	290	1,6
0,55	BOX063	i:20 + STADIO-80 + 80B-6	60	15,0	265	0,8
0,55	BOX063	i:25 + STADIO-80 + 80A-4	75	18,7	215	0,9
0,55	BOX063	i:30 + STADIO-80 + 80A-4	90	15,6	244	1,0
0,55	BOX063	i:20 + STADIO-80 + 80A-4	60	23,3	179	1,1
0,55	BOX075	i:40 + STADIO-80 + 80B-6	120	7,5	467	0,8
0,55	BOX075	i:50 + STADIO-80 + 80A-4	150	9,3	379	0,8
0,55	BOX075	i:50 + STADIO-80 + 80A-4	150	9,3	332	0,8
0,55	BOX075	i:30 + STADIO-80 + 80B-6	90	10,0	376	1,0
0,55	BOX075	i:40 + STADIO-80 + 80A-4	120	11,7	318	1,0
0,55	BOX075	i:40 + STADIO-80 + 80A-4	120	11,7	284	1,0
0,55	BOX090	i:80 + STADIO-80 + 80A-4	240	5,8	556	0,8
0,55	BOX090	i:60 + STADIO-80 + 80B-6	180	5,0	659	0,8
0,55	BOX090	i:50 + STADIO-80 + 80B-6	150	6,0	582	1,0
0,55	BOX110	i:100 + STADIO-80 + 80B-6	300	3,0	994	0,8
0,55	BOX110	i:80 + STADIO-80 + 80B-6	240	3,8	864	1,0
0,55	BOX110	i:100 + STADIO-80 + 80A-4	300	4,7	694	1,0
0,55	BOX110	i:100 + STADIO-80 + 80A-4	300	4,7	597	1,0
0,55	BOX110	i:80 + STADIO-80 + 80A-4	240	5,8	591	1,3
0,75	BOX063	i:20 + STADIO-80 + 80B-4	60	23,3	244	0,8
0,75	BOX063	i:25 + STADIO-80 + 80A-2	75	37,3	153	0,9
0,75	BOX063	i:30 + STADIO-80 + 80A-2	90	31,1	176	1,0
0,75	BOX063	i:20 + STADIO-80 + 80A-2	60	46,7	126	1,2
0,75	BOX075	i:40 + STADIO-80 + 80B-4	120	11,7	432	0,8
0,75	BOX075	i:25 + STADIO-80 + 80B-4	75	18,7	280	0,9
0,75	BOX075	i:30 + STADIO-80 + 80B-4	90	15,6	313	1,0
0,75	BOX075	i:25 + STADIO-80 + 80B-4	75	18,7	300	1,0
0,75	BOX075	i:30 + STADIO-80 + 80B-4	90	15,6	344	1,0
0,75	BOX090	i:60 + STADIO-80 + 80B-4	180	7,8	543	0,7
0,75	BOX090	i:60 + STADIO-80 + 80B-4	180	7,8	623	0,8
0,75	BOX090	i:80 + STADIO-80 + 80A-2	240	11,7	415	0,8
0,75	BOX090	i:50 + STADIO-80 + 80B-4	150	9,3	541	0,9
0,75	BOX110	i:100 + STADIO-80 + 80B-4	300	4,7	947	0,8
0,75	BOX110	i:80 + STADIO-80 + 80B-4	240	5,8	793	0,9
0,75	BOX075	i:30 + STADIO-90 + 90S-6	74	12,2	418	0,8
0,75	BOX090	i:40 + STADIO-90 + 90S-6	98	9,2	543	0,9
0,75	BOX090	i:30 + STADIO-90 + 90S-6	74	12,2	430	1,3
0,75	BOX110	i:60 + STADIO-90 + 90S-6	147	6,1	780	1,1

P ₁ [kW]		i:	n ₂ [rpm]	M ₂ [Nm]	f _s	
1,1	BOX063	i:20 + STADIO-80 + 80B-2	60	46,7	185	0,8
1,1	BOX075	i:25 + STADIO-80 + 80B-2	75	37,3	229	1,0
1,1	BOX075	i:30 + STADIO-80 + 80B-2	90	31,1	265	1,0
1,1	BOX090	i:25 + STADIO-80 + 80C-4	75	18,7	422	1,0
1,1	BOX090	i:25 + STADIO-90 + 90L-6	61	14,7	555	0,8
1,1	BOX090	i:30 + STADIO-80 + 80C-4	90	15,6	479	1,2
1,1	BOX090	i:30 + STADIO-90 + 90L-6	74	12,2	631	0,9
1,1	BOX090	i:40 + STADIO-80 + 80C-4	120	11,7	594	0,8
1,1	BOX090	i:40 + STADIO-90 + 90S-4	98	14,3	540	0,8
1,1	BOX090	i:50 + STADIO-80 + 80C-4	150	9,3	709	0,7
1,1	BOX110	i:25 + STADIO-80 + 80C-4	75	18,7	439	2,1
1,1	BOX110	i:40 + STADIO-80 + 80C-4	120	11,7	630	1,5
1,1	BOX110	i:40 + STADIO-90 + 90L-6	98	9,2	828	1,2
1,1	BOX110	i:50 + STADIO-80 + 80C-4	150	9,3	743	1,2
1,1	BOX110	i:50 + STADIO-90 + 90L-6	123	7,3	994	0,9
1,1	BOX110	i:50 + STADIO-90 + 90S-4	123	11,4	675	1,2
1,1	BOX110	i:60 + STADIO-80 + 80C-4	180	7,8	851	0,9
1,1	BOX110	i:60 + STADIO-90 + 90S-4	147	9,5	778	1,0
1,1	BOX110	i:80 + STADIO-90 + 90S-4	196	7,1	838	0,8
1,1	BOX130	i:25 + STADIO-90 + 90S-4	61	22,9	358	3,4
1,1	BOX130	i:30 + STADIO-90 + 90S-4	74	19,0	402	3,5
1,1	BOX130	i:40 + STADIO-90 + 90S-4	98	14,3	515	2,6
1,1	BOX130	i:50 + STADIO-90 + 90S-4	123	11,4	616	1,9
1,1	BOX130	i:60 + STADIO-90 + 90S-4	147	9,5	695	1,5
1,1	BOX130	i:80 + STADIO-80 + 80C-4	240	5,8	1045	0,9
1,1	BOX130	i:80 + STADIO-90 + 90S-4	196	7,0	951	1,1
1,1	BOX130	i:100 + STADIO-80 + 80C-4	300	4,7	1193	0,8
1,1	BOX130	i:100 + STADIO-90 + 90S-4	245	5,6	1134	0,8
1,5	BOX090	i:25 + STADIO-90 + 90L-4	61	22,9	504	0,8
1,5	BOX090	i:30 + STADIO-90 + 90L-4	74	19,1	574	0,9
1,5	BOX110	i:60 + STADIO-90 + 90L-4	147	9,5	948	0,8
1,5	BOX110	i:50 + STADIO-90 + 90L-4	123	11,4	922	0,9
1,5	BOX110	i:60 + STADIO-90 + 90S-2	147	19,1	567	1,0
1,5	BOX110	i:50 + STADIO-90 + 90L-4	123	11,4	827	1,1
1,5	BOX110	i:40 + STADIO-90 + 90L-4	98	14,3	766	1,1
1,5	BOX130	i:80 + STADIO-90 + 90L-4	196	7,1	1337	0,8
1,5	BOX130	i:80 + STADIO-90 + 90L-4	196	7,1	1163	0,8
1,5	BOX130	i:60 + STADIO-90 + 90L-4	147	9,5	947	1,1
2,2	BOX090	i:25 + STADIO-90 + 90L-2	61	45,7	382	

DIMENSIONAL TABLES



DIMENSIONAL TABLES

BOX input and combinations

BOX type	motor type		Nm	Mm	Pm	Dm	i										
							7,5	10	15	20	25	30	40	50	60	80	100
BOX025	56	B14	50	65	80	9											
	56	B14	50	65	80	9											
BOX030	63	B5	95	115	140	11											
	63	B14	60	75	90	11											
BOX040	63	B5	95	115	140	11											
	71	B14	60	75	90	14											
		B5	110	130	160	14											
BOX050	63	B5	95	115	140	11											
	71	B14	60	75	90	14											
		B5	110	130	160	14											
	80	B14	70	85	105	19											
BOX063	71	B5	110	130	160	14											
	80	B14	70	85	105	19											
		B5	130	165	200	19											
	90	B14	80	100	120	24											
BOX075	80	B5	130	165	200	19											
	90	B14	80	100	120	24											
		B5	130	165	200	24											
	100/112	B14	95	115	140	28											
BOX090	80	B5	180	215	250	19											
	90	B14	110	130	160	24											
		B5	130	165	200	24											
	100/112	B14	95	115	140	28											
BOX110	90	B5	180	215	250	24											
	100/112	B14	110	130	160	28											
		B5	230	265	300	38											
	132	B5	130	165	200	38											
BOX130	90	B14	95	115	140	24											
	100/112	B5	180	215	250	28											
		B14	110	130	160	28											
	132	B5	230	265	300	38											
BOX150	100/112	B5	180	215	250	28											
	132	B5	230	265	300	38											
	160	B5	250	300	350	42											

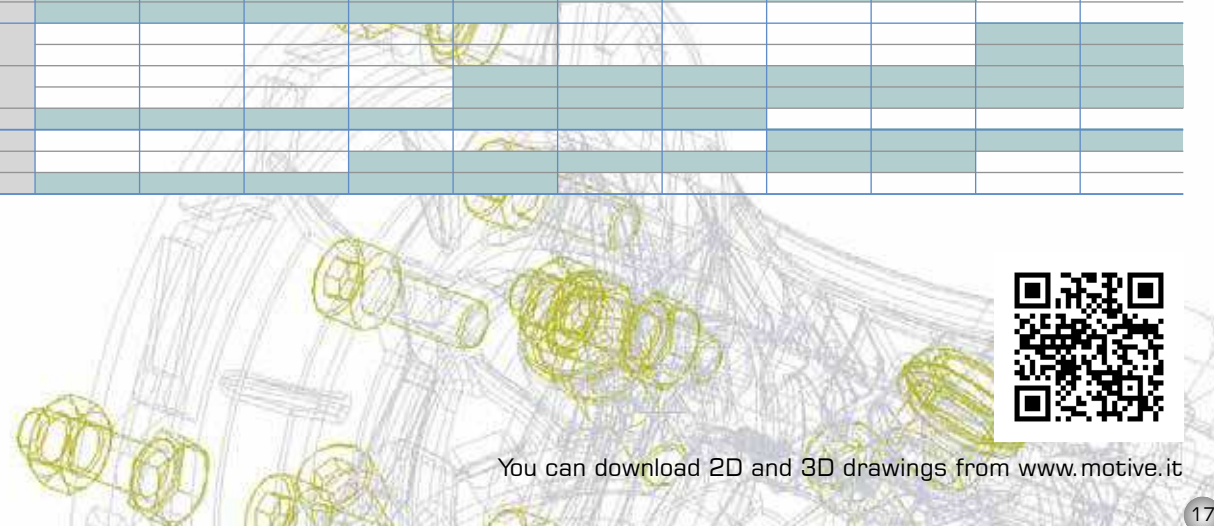
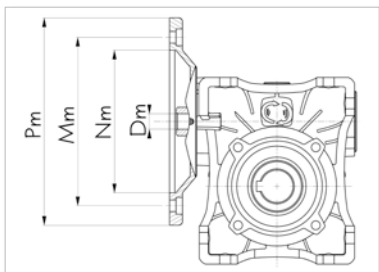

You can download 2D and 3D drawings from www.motive.it

DIMENSIONAL TABLES

STADIO + BOX combinations

	STADIO-63		STADIO-71		STADIO-80		STADIO-90	
motor flange	63B5		71B5		80/90B5			
P1	140		160		200			
box flange	71B14		80B14		100B14			
P	105		120		160			
output shaf diameter	D1	D2	D1	D2	D1	D2	D1	D2
i	11	14	14	19	19	24	24	28
	i:2,93	i:2,93	i:2,94	i:2,94	i:3	i:3	i:2,45	i:2,45

BOX040	25							
	30							
	40							
	50							
	60							
BOX050	80							
	100							
	25							
	30							
	40							
BOX063	50							
	60							
	80							
	100							
	25							
BOX075	30							
	40							
	50							
	60							
	80							
BOX090	100							
	25							
	30							
	40							
	50							
BOX110	60							
	80							
	100							
	25							
	30							
BOX130	40							
	50							
	60							
	80							
	100							

Box B14 motor B5

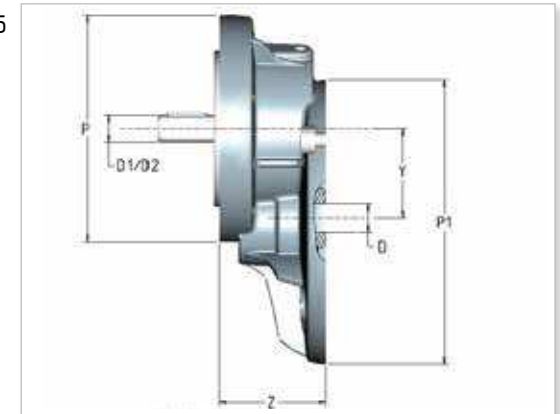

	input			output					
	motor flange	P1	D	BOX flange	P	D1	D2*	Y	Z
STADIO-63	63B5	140	11	71B14	105	11 (IEC63)	14 (IEC71)	43	47
STADIO-71	71B5	160	14	80B14	120	14 (IEC71)	19 (IEC80)	54	55
STADIO-80	80B5	200	19	100B14 (=71B5)	160	19 (IEC80)	24 (IEC90)	66	75
STADIO-90	90B5	200	24	100B14 (=71B5)	160	24 (IEC90)	28 (IEC100)	66	75

*if D2 instead of D1 is required, specify it in the order

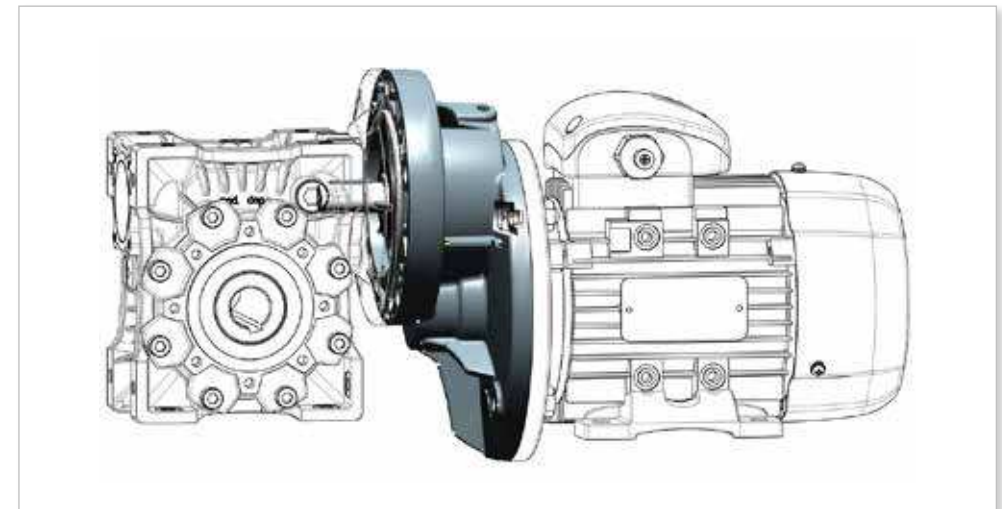

DIMENSIONAL TABLES

BOX general data

Box type	A	C	G	H	I	K	KE	L	M	N (h8)	N1	O	P	Q	R	S	V	W	T	G1	D (h7)	output		MB/MF						Kg	
																						b	t	B	D1 (j6)	G2	G3	b1	t1		f
BOX025	45	70	45	35	25	34	Ø6,5 (n°3 through holes)	42	55	45 (h9)	22,5	6	-	35,5	48	5	22,5	-	16	50	11	4	12,8	-	-	-	-	-	-	-	0,7
BOX030	54	81	55	40	30	44	M6x11 (n°4)	56	65	55	29	6,5	75	44	57	5,5	27	-	20	63	14	5	16,3	20	9	51	45	3	10,5	-	1,2
BOX040	70	101	70	50	40	60	M6x10 (n°4)	71	75	60	36,5	6,5	87	55	71,5	6,5	35	45°	23	78	18 (19)	6	20,8 (21,8)	23	11	63	53	4	12,5	-	2,7
BOX050	80	121	80	60	50	70	M8x10 (n°4)	85	85	70	43,5	8,5	100	64	84	7	40	45°	30	92	25 (24)	8	28,3 (27,3)	30	14	77	64	5	16	M6	3,6
BOX063	100	146	96	72	63	85	M8x14 (n°8)	103	95	80	53	8,5	110	80	102	8	50	45°	40	112	25 (28)	8	28,3 (31,3)	40	19	90	75	6	21,5	M6	7,8
BOX075	120	173	112,5	86	75	90	M8x14 (n°8)	113	115	95	57	11	140	93	119	10	60	45°	50	120	28 (35)	8 (10)	31,3 (38,3)	50	24	107	90	8	27	M8	9
BOX090	140	208	129,5	103	90	100	M10x18 (n°8)	130	130	110	67	13	160	102	135	11	70	45°	50	140	35 (38)	10	38,3 (41,3)	50	24	125	108	8	27	M8	13
BOX110	170	255	162,5	127,5	110	115	M10x18 (n°8)	144	165	130	74	14	200	125	167,5	15	85	45°	60	155	42	12	45,3	60	28	147	135	8	31	M10	38
BOX130	200	292,5	180	147,5	130	120	M12x21 (n°8)	155	215	180	81	16	250	140	187,5	15,5	100	45°	60	170	45	14	48,8	80	30	165	155	8	33	M10	52
BOX150	240	340	210	170	150	145	M12x21 (n°8)	185	215	180	96	18	250	180	230	18	120	45°	72,5	200	50	14	53,8	80	35	198	175	10	38	M12	91

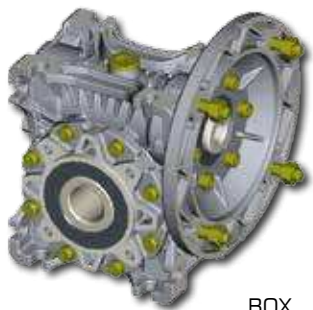
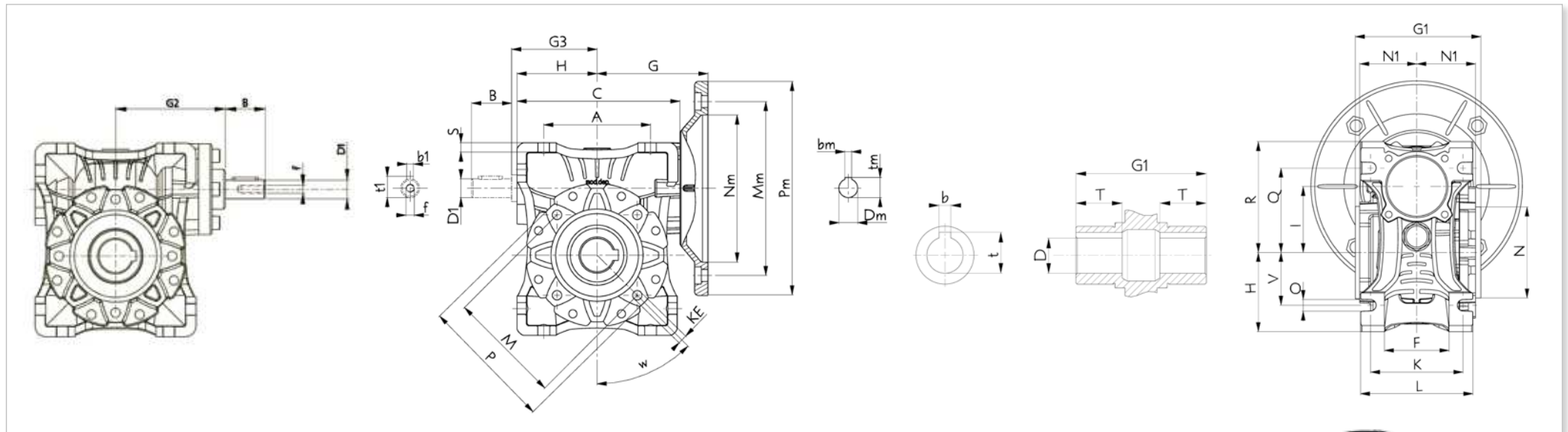

BOX



BOX + MF



BOX + MB

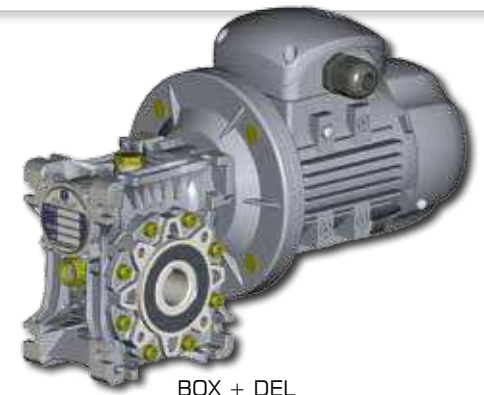

BOX + DEL

DIMENSIONAL TABLES

type	output flange F									output flange FL								
	KA	KB	KC	KM	KN (h8)	KO	KP	KQ	KW	KA	KB	KC	KM	KN	KO	KP	KQ	KW
BOX025	45	5	2,5	55	40	6,5 (n°4)	75	70	45°	-	-	-	-	-	-	-	-	-
BOX030	54,5	6	4	68	50	6,5 (n°4)	80	70	45°	-	-	-	-	-	-	-	-	-
BOX040	67	7	4	75	60	9 (n°4)	110	95	45°	97	7	4	75	60	9 (n°4)	110	95	45°
BOX050	90	9	5	85	70	11	125	110	45°	120	9	5	85	70	11 (n°4)	125	110	45°
BOX063	82	10	6	150	115	11	180	142	45°	112	10	6	150	115	11 (n°4)	180	142	45°
BOX075	111	13	6	165	130	14	200	170	45°	-	-	-	-	-	-	-	-	-
BOX090	111	13	6	175	152	14	210	200	45°	-	-	-	-	-	-	-	-	-
BOX110	131	15	6	230	170	14	280	260	22,5°	-	-	-	-	-	-	-	-	-
BOX130	140	15	6	255	180	16	320	290	22,5°	-	-	-	-	-	-	-	-	-
BOX150	155	15	6	255	180	16	320	290	22,5°	-	-	-	-	-	-	-	-	-



BOX + F/FL

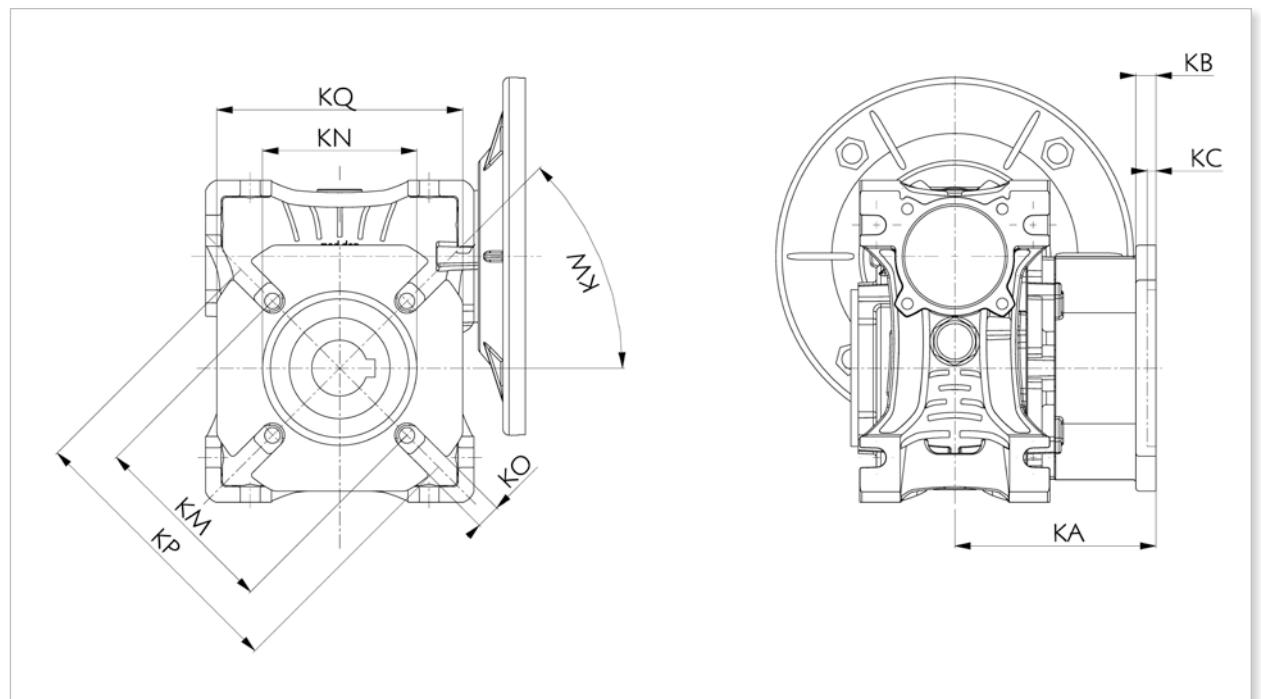

DIMENSIONAL TABLES

Accessories

Torque arm

Type	K1	G	KG	KH	R
BOX025	70	14	17,5	8	15
BOX030	85	14	24	8	15
BOX040	100	14	31,5	10	18
BOX050	100	14	38,5	10	18
BOX063	150	14	49	10	18
BOX075	200	25	47,5	20	30
BOX090	200	25	57,5	20	30
BOX110	250	30	62	25	35
BOX130	250	30	69	25	35
BOX150	250	30	84	25	35

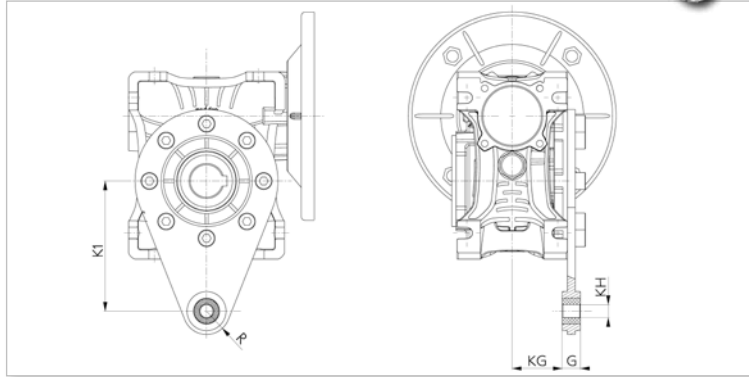
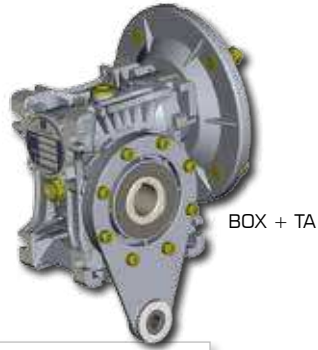

Single and double output shaft

Type	d (h6)	B	B1	G1	H	L1	f	b1	t1
BOX025	11	23	25,5	50	8	101	-	4	12,5
BOX030	14	30	32,5	63	8	128	M6	5	16
BOX040	18	40	43	78	9	164	M6	6	20,5
BOX050	25	50	53,5	92	13	199	M10	8	28
BOX063	25	50	53,5	112	13	219	M10	8	28
BOX075	28	60	63,5	120	15	247	M10	8	31
BOX090	35	80	84	140	15	308	M12	10	38
BOX110	42	80	84,5	155	15	324	M16	12	45
BOX130	45	80	85	170	15	340	M16	14	48,5
BOX150	50	82	87	200	15	374	M16	14	53,5

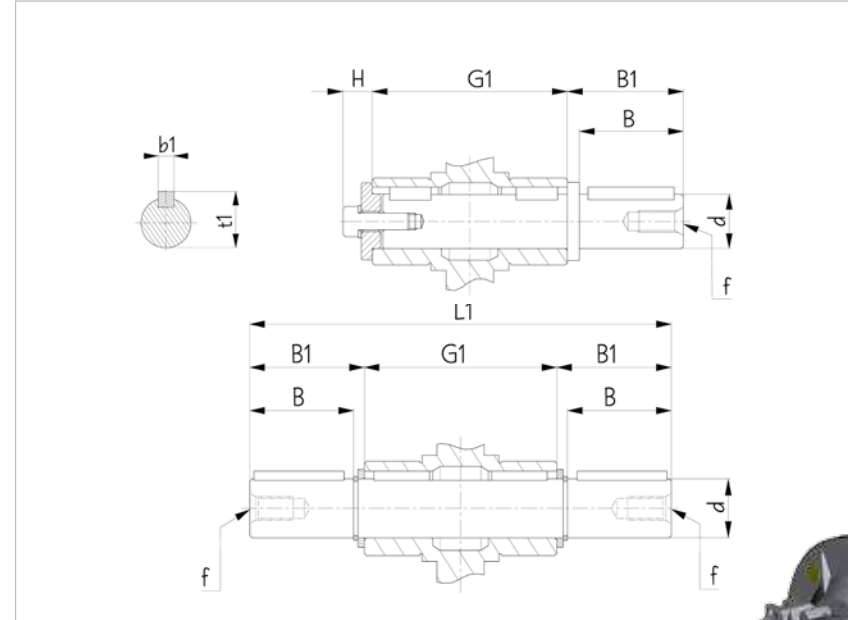

Combined

BOX + BOX	K	I1	I2	G4
BOX030+BOX040	120	30	10	198
BOX030+BOX050	130	30	20	218
BOX030+BOX063	145	30	63	245
BOX040+BOX075	164,5	40	35	286
BOX040+BOX090	182,5	40	50	321
BOX050+BOX110	227,5	50	60	397,5
BOX063+BOX130	245	63	67	444

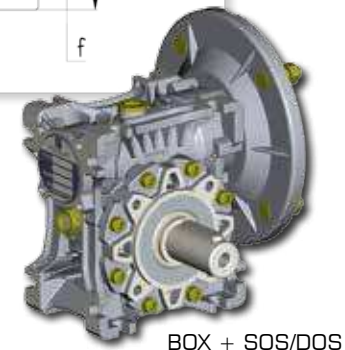
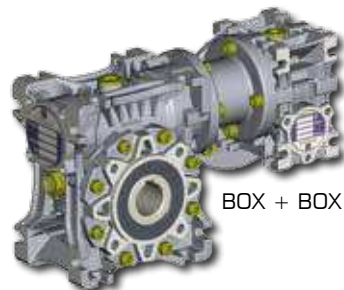
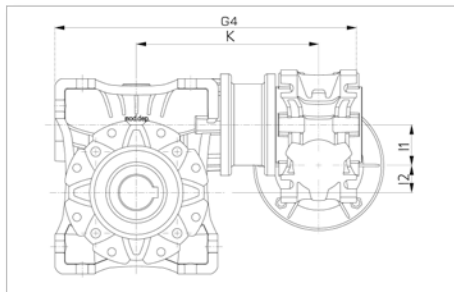

COMPONENTS LIST

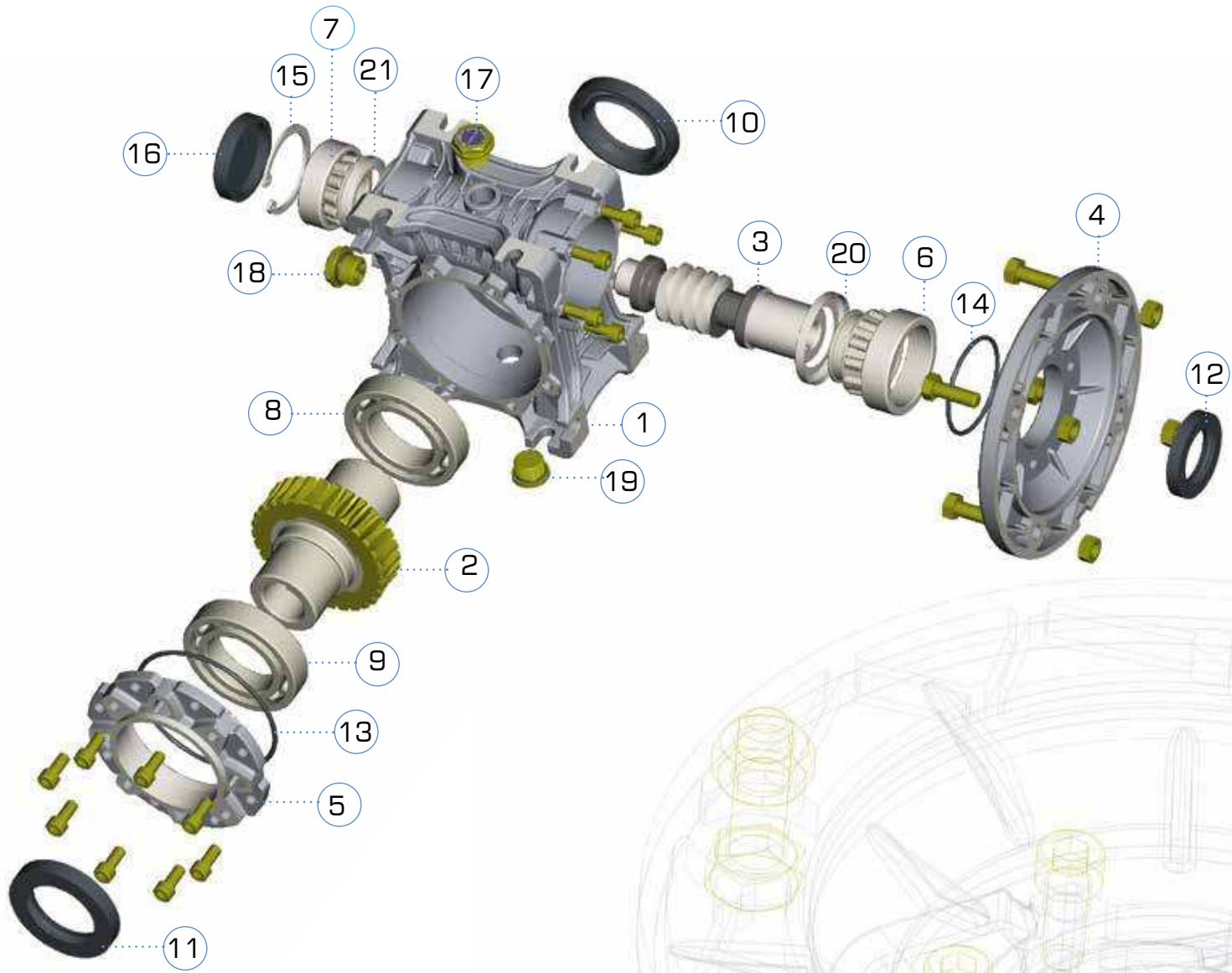

N°	CODE
1	BOXHOU
2	BOXGEA
3	BOXSHA
4	BOXFLA
5	BOXCAP
6	BOXB06
7	BOXB07
8	BOXB08
9	BOXB09
10	BOXS10
11	BOXS11
12	BOXS12
13	BOXS13
14	BOXS14
15	BOXSEE
16	BOXCOV
17	BOXBPL
18	BOXLPL
19	BOXFPL
20	BOXN20
21	BOXN21

OIL SEAL RINGS AND BEARINGS LIST

Mounting position: any

	bearings				oil seals		
	6	7	8	9	10	11	12
BOX 25	61803	6000-ZZ	61904	16004	20×32×6	20×42×6	16×24×7
BOX 30	61904	6002-ZZ	6005	6005	25×47×7	25×47×7	20×30×7
BOX 40	6005	6203-ZZ	6006	6006	30×40×7	30×40×7	25×35×7
BOX 50	6006	6204-ZZ	6008-ZZ	6008-ZZ	40×62×8	40×62×8	30×47×7
BOX 63	6007	6205-ZZ	6009-ZZ	6009-ZZ	45×65×8	45×65×8	35×52×10
BOX 75	32008+NILOS	30206+NILOS	6010-ZZ	6010-ZZ	50×72×8	50×72×8	40×60×10
BOX 90	32008+NILOS	30206+NILOS	6012-ZZ	6012-ZZ	60×85×10	60×85×10	40×60×10
BOX110	32010+NILOS	32207+NILOS	6013-ZZ	6013-ZZ	65×85×8	65×85×8	50×68×8
BOX130	32010+NILOS	32207+NILOS	6014-ZZ	6014-ZZ	70×90×10	70×90×10	50×68×8
BOX150	30212+NILOS	30209+NILOS	6018-ZZ	6018-ZZ	90×120×12	90×120×12	60×90×10

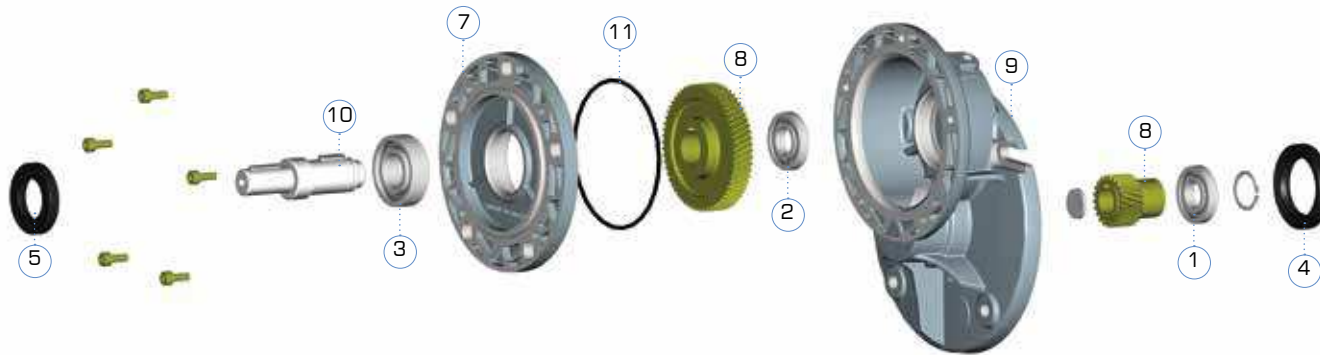

N°	CODE
1	BEA...
2	BEA...
3	BEA...
4	OS...
5	OS...
6	STAHOU
7	STAB14
8	STAPIN
9	STAGEA
10	STASHA
11	STAS11

part nr		STADIO-63		STADIO-71		STADIO-80		STADIO-90		
	bearing	oil seal	BEA	OS	BEA	OS	BEA	OS	BEA	OS
input	1	4	16004	19x42x6	6005	24x47x6	6206	30x62x7	6007	35x62x7
output	2	5	6002	17x30x7	6003	20x35x7	6006	30x47x7	6006	30x47x7
	3		16003		16004		6006			