

Chromalox®

Installation and OPERATING INSTRUCTIONS

SERVICE REFERENCE

DIVISION 4		SECTION CIT	
SALES REFERENCE (Supersedes PD412-4)		PD412-5	
161-049179-001			
DATE		MAY, 1999	

Type CIT Cast Iron, Metal Melting, Immersion Heaters Maximum Melt Temperature — 950°F

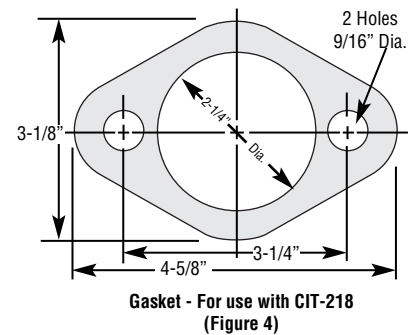
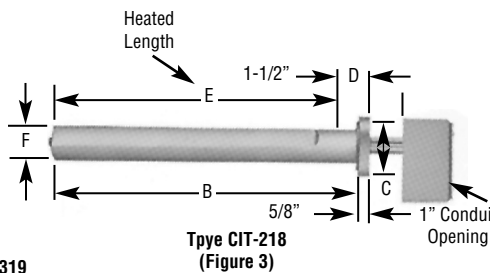
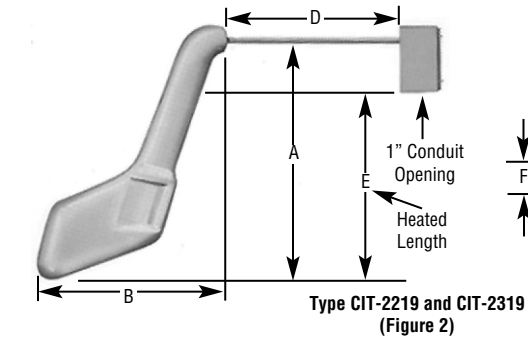
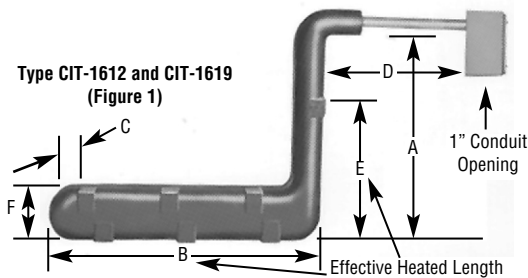

Specifications

Model	Volts	kW	Displacement Volume (In ³)	Dimensions (In.)					
				A	B	C	D	E	F
CIT-218	240	3	57	—	18	4-5/8	2	17-3/8	2
CIT-1612	240	5	135	12-1/4	16	2	9	10	3
CIT-1619	240	5	180	19-1/4	16	2	6	17	3
CIT-2219	240	5	145	18-1/2	12-1/2	—	6-1/2	14-1/2	—
CIT-2319	240	10	180	19	15-1/4	—	9	15	—

GENERAL

WARNING: Hazard of Shock. Disconnect all power before installing, servicing or replacing heaters.

Chromalox Cast-Iron Immersion Heaters are generally used for metal-melting applications such as solder, lead, tin, stereotype metal, babbitt (with 4% or less copper) and other soft metals where maximum working temperature is 950 °F.

Note: Not suitable for immersion in zinc or aluminum.

- Heater Construction Characteristics —
 - High quality resistance wire held in place by compacted magnesium oxide in heavy wall steel sheath cast in iron.
 - Large heat output at relatively low watt densities.
 - Excellent heat transfer.

D. A rugged, cast iron terminal box protects the terminals against spillage and abuse.

WARNING: Users should install adequate back-up controls and safety devices with their electric heating equipment. Where the consequences of failure may be severe, back-up controls are essential, including GFCI (Ground Fault Circuit Interrupters). Although the safety of the installation is the responsibility of the user, Chromalox will assist in identifying equipment options.

INSTALLATION

- Before installing the type CIT heater, inspect it for possible damage which may have occurred during shipment. Also, check to insure that the line voltage is the same as that stamped on the nameplate.
- CAUTION:** Mount heater in the tank so that the liquid level will always be above the effective heated portion of the heater. If the heater is not properly submerged, it will overheat and damage the heating elements and create a possible fire hazard due to excessive sheath temperatures.

WARNING: When melting solids by direct immersion, a surface vent should be provided to allow gases to escape.

A. Over-the-Side

Models CIT-1612 and CIT-1619 (see Figure 1 - for use in flat bottomed and straight-sided vessels); CIT-2219 and CIT-2319 (See Figure 2 - for use in sloping vessels) are designed for over-the-side installation.

- To resist buoyancy of heater in heavy metals, securely mount heater to metal crucible by clamping.

CAUTION: Do not support or suspend heater by the tubular section adjacent to the terminal box as the tubular section will be damaged by bending.

INSTALLATION

B. Through-the-Wall

Model CIT-218 (Figure 3) is designed for through-the-wall installation.

1. To install, drill three holes in side of crucible at proper height using hole dimensions shown in Figure 4 or by using gasket enclosed with heater as a template.
2. Insert heater first through gasket and then through tank wall opening making sure that gasket is firmly seated between heater flange and tank wall.

3. Using standard hardware bolts and nuts consistent with the hole diameter and the tank wall thickness, secure heater into place.

DANGER: Hazard of Fire. - Since these heaters are capable of developing high temperatures, extreme care should be taken to:

- A. Avoid installing heaters in an atmosphere containing combustible gases and vapors.
- B. Avoid contact between heater and combustible material.
- C. Keep combustible materials far enough away to be free of the effects of high temperatures.

WIRING

WARNING: Hazard of Shock. Any installation involving electric heaters must be effectively grounded in accordance with the National Electrical Code to eliminate shock hazard.

1. Electrical wiring to heater must be installed in accordance with the National Electrical Code and with local codes by a qualified person as defined in the NEC.

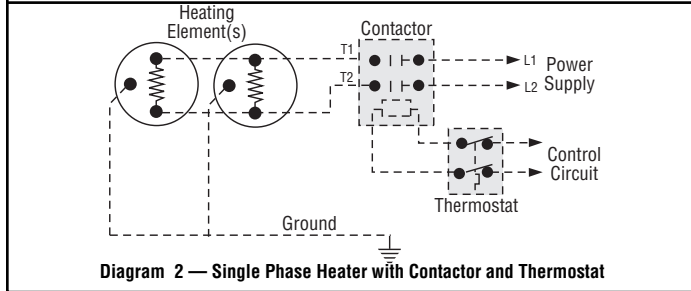
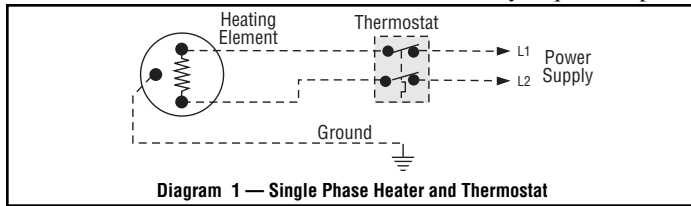

2. When element wattages are not equal, heaters must not be connected in series.
3. Electrical wiring to heater should be contained in rigid conduit or in sealed flexible hose to keep corrosive vapors and liquids out of the terminal housing. If high humidity is encountered, the conduit should slope away from the heater.
4. If flexible cord is employed, a watertight connector should be used for entry of the cord into the terminal box. Outdoor applications require liquid-tight conduit and connectors.
5. Bring the power line wires through the opening in the terminal box. Connect line wires as shown in the appropriate wiring diagrams (see Diagrams 1, 2 and 3).

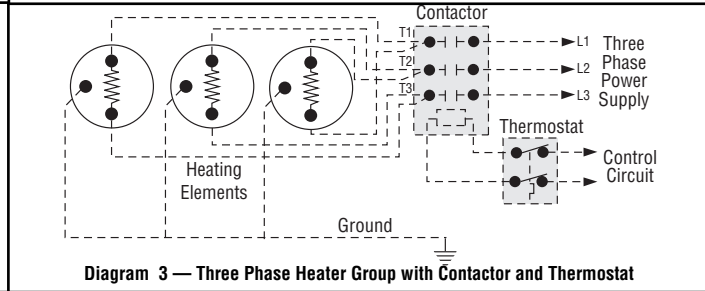

OPERATION

1. Do not operate heaters at voltages in excess of that stamped on the heater since excess voltage will shorten life.
2. Always maintain 6" to 8" of liquid above the heated portion of the element to prevent exposure of the effective heated length. If the heater is not properly submerged, it may overheat and shorten heater life. **DO NOT OPERATE HEATER IF DRY.**
3. Sludge should not be allowed to buildup to the point where it contacts heater as this can lead to premature heater failure.
4. Buildup of dross accumulation on the surface of liquid metal should be prevented to insure satisfactory operation of the heater.
5. When melting solids by direct immersion, a surface vent should be provided to allow gases to escape.

MAINTENANCE

WARNING: Hazard of Shock. Disconnect all power to heater before servicing or replacing heaters.

1. Heaters should be checked periodically for coatings and corrosion and cleaned if necessary.
2. The tank should be checked regularly for sediment around the heater as sediment can act as an insulator and shorten heater life.
3. Remove any accumulated sludge deposits from heater and from tank.
4. Check for loose terminal connections and tighten if necessary.
5. If corrosion is indicated in the terminal housing, check terminal box gasket and replace if necessary. Check conduit layout to correct conditions that allow corrosion to enter the terminal housing.
6. Clean terminal ends of all contamination.

Limited Warranty:

Please refer to the Chromalox limited warranty applicable to this product at <http://www.chromalox.com/customer-service/policies/terms-of-sale.aspx>.

Chromalox[®]
PRECISION HEAT AND CONTROL

2150 N. RULON WHITE BLVD., OGDEN, UT 84404
Phone: 1-800-368-2493 www.chromalox.com