

MESSRS :

Instruction Manual

CUSTOMER'S PRODUCT NAME:

TDK-Lambda PRODUCT NAME: DC-DC Converter Unit ALD-414012PJ133

TDK-Lambda

TDK-Lambda Corporation

PREPARED BY	APPROVED BY	AUTHORIZED BY
<i>Apr. 11, 2013 K.Oshima</i>	<i>Apr. 11, 2013 Y.Miyaoka</i>	<i>Apr. 11, 2013 H.Masuoka</i>

DWG.No.	CTR-4475-X
---------	------------



Precautionary Notes Regarding the Use of This Converter

When using this product, give due consideration to the precautionary notes described below and ensure a safe design. Inappropriate use may result in electric shock, injury or fire.

Caution

This product is designed for driving LED backlight systems.
Do not use it with any other load.
Store this product under the conditions defined in the specification document.
Do not store this product in an environment where dust, dirt or corrosive gas(salt,acid,base, etc.) is present.
This product is designed for use with general electronic equipment.
If it is to be used with medical equipment that directly affects human life or for the control of transportation equipment to which passengers entrust their lives, provide thorough fail-safe measures.
Avoid using this product under high temperatures or high humidity or in an environment in which dust, dirt or any corrosive gas (salt,acid,base, etc.) is present.
Also, be careful not to allow the formation of dew condensation. It may result in damage or electric shock.
If the product does not have a built-in protective circuit (circuit breaker, fuse, etc.), it is recommended that a fuse be used at the input stage to prevent the occurrence of smoke or fire in the event of a malfunction.
Even when the product has a built-in protective circuit (circuit breaker, fuse, etc.), the circuit may not function properly due to inappropriate operating conditions or power-supply capacity.
It is recommended that an appropriate protective circuit (circuit breaker, fuse, etc.) be provided separately from the built-in circuit.
Use the product only within the specified input voltage, output voltage, and operating temperature ranges. Exceeding these values may result in damage, etc.
Provide a measure for the prevention of surge voltage due to lightning, etc.
Abnormal voltage may result in damage, etc.
This product is not designed to provide resistance to radiation.
Ripples could be superimposed on the voltage and the current in the input source connected to the inverter, depending on the impedance in the input source, wiring, etc.
When you select an input source, please check waveforms, etc on the final set.
This product doesn't have the input overvoltage protection circuit. If there is a possibility that the surge voltage is impressed to the input, please do the surge prevention measures.
Please do not remodel and do not process it. Our company doesn't assume the responsibility of those things.
Please attentionnote the safe design enough. Especially, do not cause the troubles such as the accident causing injury or deaths and fire accidents.

Handling Precautions

Do not stack multiple products on top of one another.
Do not allow the product to come in contact with tools, etc.
Do not apply excessive stress during installation.
It may cause chipping and cracking, resulting in damage, etc.
Please do not use the product, if it has been dropped because there is the possibility of component damage.



1 Reference Application Circuit

1-1 Example1

*Connecting method:

Set the high level current which connects fixed resistance (R1) to ADIM terminal from GND,
Set the Duty which connects variable resistance (VR1) to Vbr/Rbr terminal from GND,
Connect the switch (SW1) as remote function to Vrmt terminal from Vin,
Open the Vst terminal which does not used the alarm function.

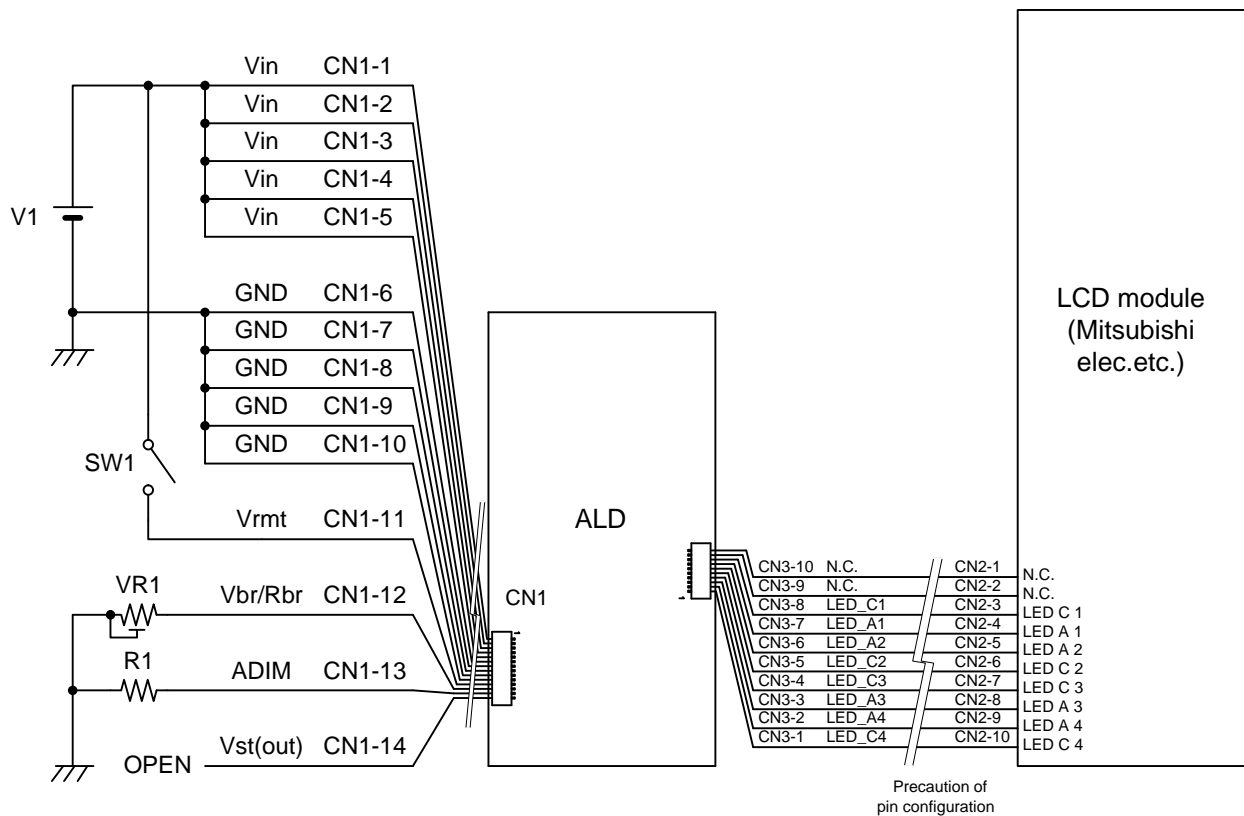

Fig 1-1 Connection diagram1

Table1-1 Parts list (reference)

Symbol	Value	Note
V1	12V	Power Supply
SW1	-	Rating DC15V 10mA or more
VR1	50kohm	Tolerance $\pm 20\%$ or less Rating power 10mW or more
R1	Refer to Table 1-2	Tolerance $\pm 1\%$ or less Rating power 50mW or more



DC-DC Converter Unit ALD-414012PJ133 Instruction Manual

*The determination method of external parts (Example1)

First, set the high level “Iop” of the LED passes current “Iout (=If).”
In the example of Liquid Crystal display Module (LCM) specification of Table 1-2, since it is indicated as “standard 120mA”, thus, Iop=120mA.

Table 1-2 The written example of the LED section in LCM specifications

Item	Symbol	Minimum	Typical	Maximum	Unit
LED current	IF	--	120	130	mA

Second, in order to set up Iop with an ADIM terminal, connect the resistance of Table 1-3
From Table 1-3, 470 ohms is connected between ADIM-GND at the time of Iop=120mA.

Table 1-3 ADIM terminal connecting resistance value (reference)

Iop [mA]	ADIM - GND resistance [ohm]	Iop [mA]	ADIM - GND resistance [ohm]
140	0	65	2.7k
130	220	60	3.3k
120	470	50	4.3k
110	750	40	5.6k
100	1.1k	30	7.5k
90	1.5k	Below the above	It cannot set in resistance. (voltage only)
80	2.0k		
70	2.6k		

Finally, in order to be able to adjust brightness by a variable resistor, Variable resistor VR1 of Table 1-1 is connected between Vbr/Rbr-GND.
The current waveform Iout (=If) which flows into LED when it sets above-mentioned up is shown in Fig. 1-2.
If V1 is supplied and SW1 is turned on, ALD will operate and LED will light up.
If VR1 is turned, by PWM dimming, the rate (Duty) of time to send current or not send it through LED changes, and it can change brightness.

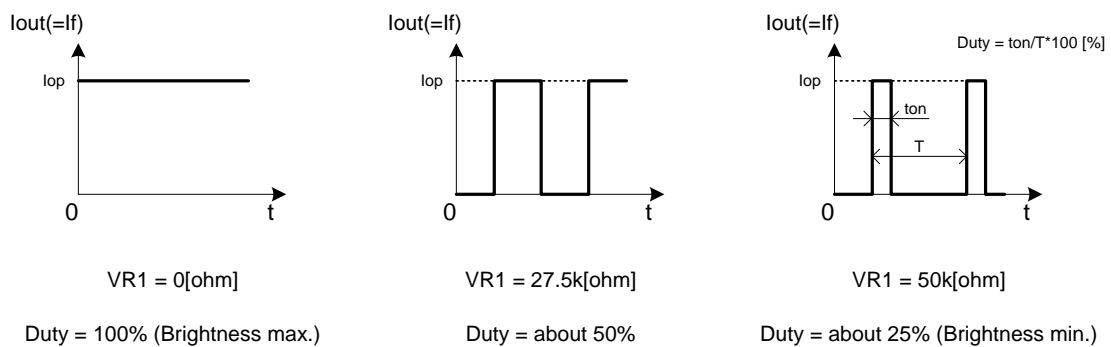

Fig 1-2 LED current waveform in the PWM dimming



1-2 Example2

*Connecting method:

The PWM signal is smoothed by R2,R3,C1,C2, then it is buffered by U1, connected by Vbr/Rbr terminal through R6.

The DAC signal is buffered by U2, connected by ADIM terminal through R7.

The output port signal is connected by Vrmt terminal through R1.

The input port is connected by Vst terminal through R5.

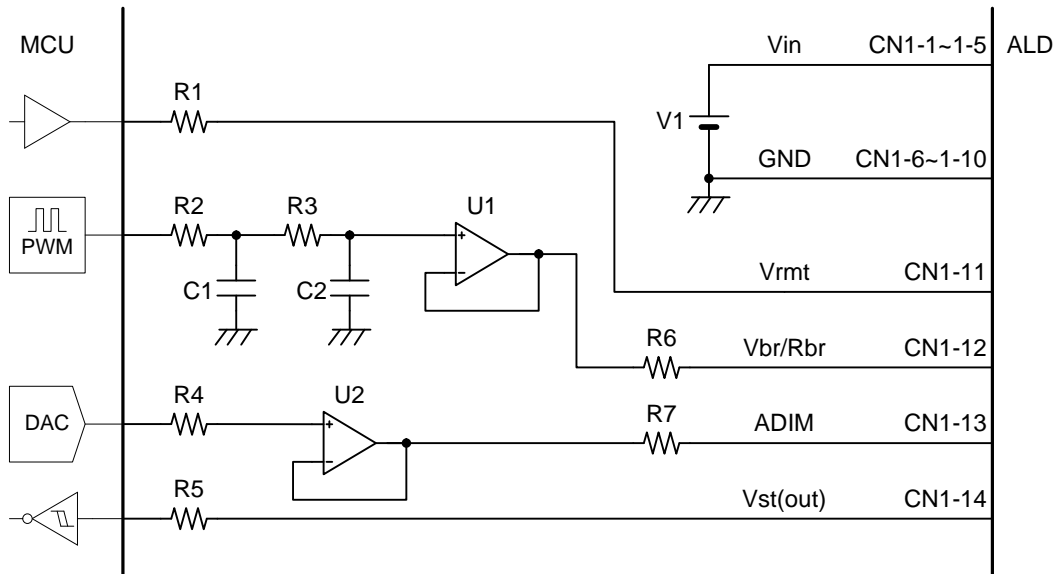

Fig 1-3 Connection diagram 2

Table 1-4 Parts list 2 (reference)

Symbol	Value	Note
V1	12V	Power Supply
C1,C2	0.1uF	C1005X7R1C104K (TDK-EPC)
R1	4.7kohm	Tolerance $\pm 5\%$ or less Rating power 50mW or more
R4,R5	47kohm	
R2,R3	100kohm	
R6,R7	100ohm	
U1,U2	-	LM358

Table 1-5 Signal list 2 (reference)

Symbol	Value	Note
PWM	0-100%	3.3V, 1kHz
DAC	0-2.5V	-

*A flicker may occur in LED when the dimming terminal (Vbr/Rbr, ADIM) voltage has some ripple.

*The determination method of MCU output signals (Example2)

From the characteristic of Fig 2-3, at the time of $I_{op}=120mA$, since ADIM terminal voltage is corresponds to 0.45V, the DAC output voltage level is set to the voltage.

In order to do PWM dimming of LEDs, Duty of the PWM pulse of MCU is adjusted so that Vbr/Rbr terminal voltage can carry out variable in the range which is 0-2.5V.

Vrmt terminal voltage is set to Hi and LED is turn on after a setup. Refer to "5 Recommended Operating Sequence".

In addition, if it carries out variable of the ADIM terminal voltage by 0.4V to 2.5V, dimming range becomes large.

Please confirm whether there are a flicker and un-switching on the light at the time of dimming.



1-3 Example3

*Connecting method:

In order to make a dimming range expand, Vbr/Rbr and ADIM terminal are connected to R1, R2, R4, VR1 with reference to Fig 1-4.

A logic of Vrmt can invert with reference to Fig 1-4.

When Vst is high (alarm output becomes active), the alarm LED lights.

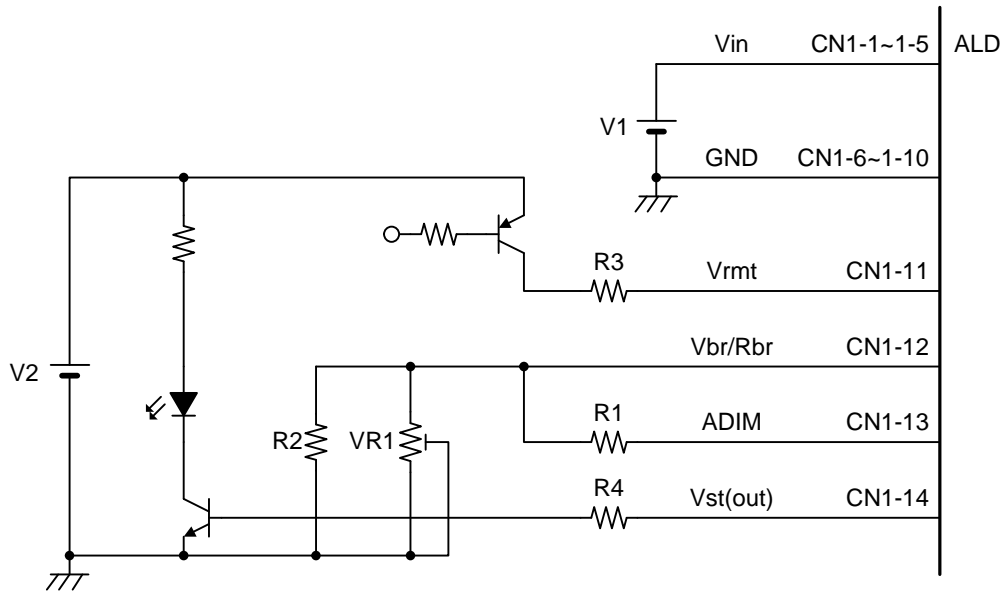

Fig 1-4 Connection diagram 3

*A flicker may occur in LED when the dimming terminal (Vbr/Rbr, ADIM) voltage has some ripple.

Table 1-6 Parts list 3 (reference)

Symbol	Value	Note
V1	12V	Power Supply
V2	3.3 or 5V	Power Supply
R1	Refer to Table 1-2	Tolerance $\pm 1\%$ or less
R2	20k ohm	Rating power 50mW or more
R3	4.7k ohm	Tolerance $\pm 5\%$ or less
R4	47k ohm	Rating power 50mW or more
VR1	10k ohm	Tolerance $\pm 20\%$ or less Rating power 20mW or more

*The determination method of external parts (Example3)

Please refer to Table 1-3, Set up Iop value of LED current. LEDs can dim by control of VR1. However, this connection method, the dimming characteristics may not become linear. In addition, the Vbr terminal voltage should set up R2 not to exceed 2.5V. Please confirm whether there are a flicker and un-switching on the light at the time of dimming.



2 Dimming Characteristics

*The ALD is able to adjust the PWM dimming brightness by the Vbr/Rbr terminal and current dimming by the ADIM terminal.

*Average current of LEDs is shown by the following formula:

$$[\text{High level current by the ADIM setting}] \times [\text{Duty by the Vbr/Rbr setting}]$$

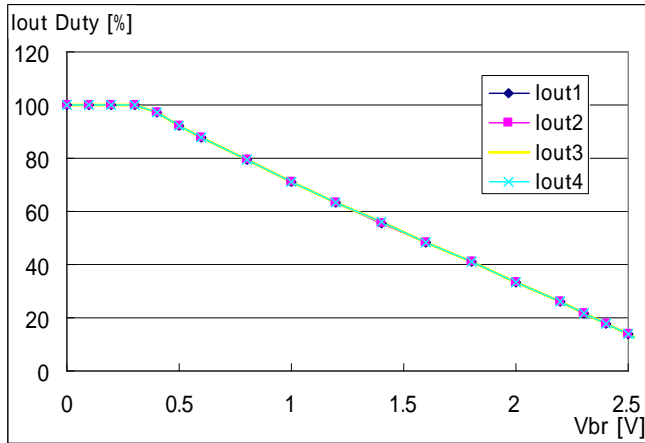

Fig. 2-1 PWM dimming characteristics (Vbr vs Duty)

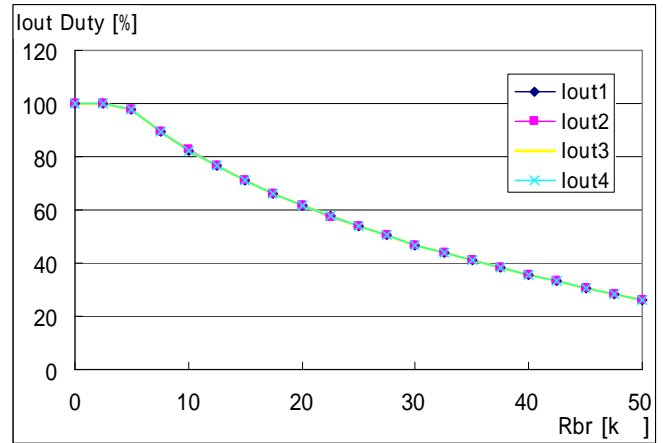

Fig. 2-2 PWM dimming characteristics (Rbr vs Duty)

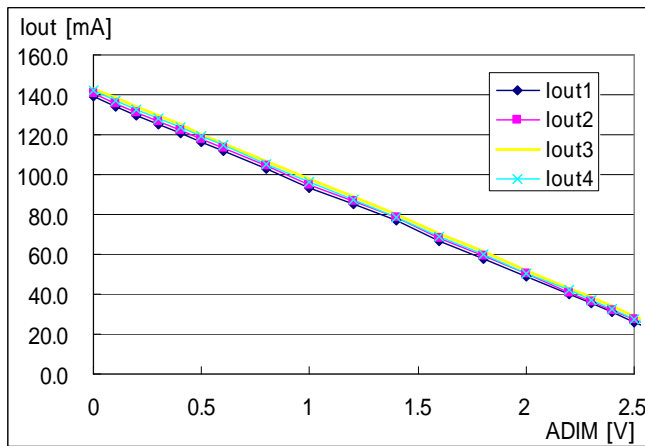

Fig. 2-3 Current dimming characteristics (ADIM vs lout)



3 Output voltage derating

Please refer to Figure 3-1 for the voltage derating of the product.

Use the product in the derating curve of the Ambient temperature (near by CN1) and the Vout condition.

Also need actual evaluation of surface temperature of the ALD mounting part before using it. The test part and limit value is described in the Product Drawing. Please measure temperature in worst condition (input voltage, load voltage, mounting instruction, and temperature).

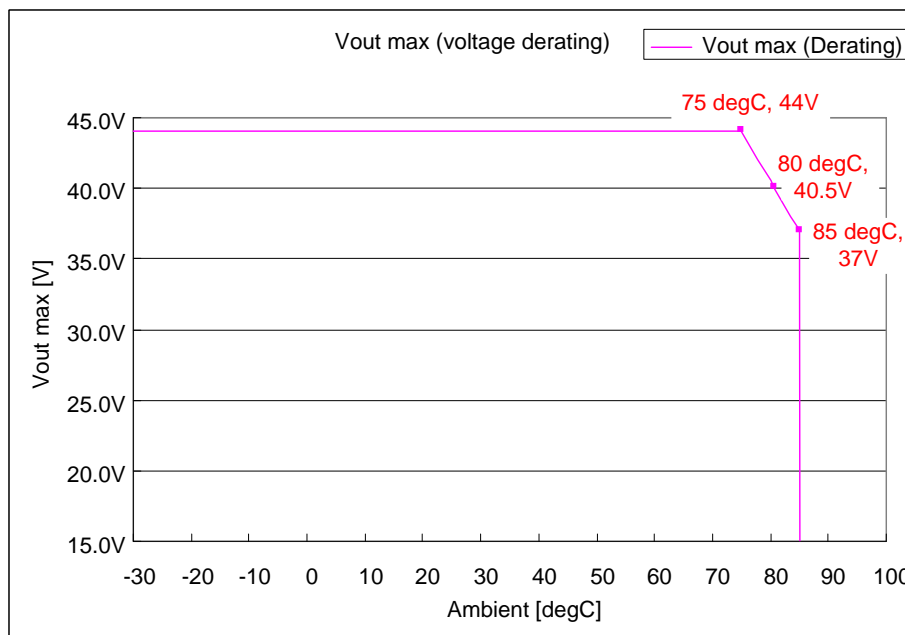

Fig.3-1 Output derating



4 Protection function

*The ALD is equipped with the following protection circuits:

- (1) Open LED protection circuit (Alarm output)
- (2) Over voltage protection circuit (Alarm output)
- (3) Input over current protection circuit (Fuse blows)
- (4) Output A-C short protection circuit

4-1 Open LED protection circuit

The Open LED protection circuit and the over voltage protection circuit are the same circuit.

If one of the LED strings is open, the opened string keeps working in an over voltage condition and the other strings work normally.

The alarm output is Hi (around 5V) when any string is in an open condition.

4-2 Over voltage protection circuit

When over voltage protection circuit operates, the unit keeps on working at over voltage threshold voltage.

The alarm output is Hi (around 5V) when any strings work at over voltage condition.

4-3 Input over current protection circuit

The ALD has an internal over current protector for the input.

Please ensure power supply capacity on the Product Drawing for proper operation of over current protector.

Please confirm input current on the final products does not exceed the Product Drawing in any conditions.

When you cannot use the power supply capacity, please prepare other external over current protection device because the circuit protector may not work properly.

4-4 Output A-C short protection circuit

This ALD has a short protection circuit between the Anode and the Cathode output terminal.

However the product may be damaged at this condition.

Please do not use the short-circuited product even once.



5 Recommended Operating Sequence

*Please refer to Figure 5-1 for the recommended operating sequence. Also the ALD has an alarm output function. The Alarm output is 0~1V at normal condition and around 5V at abnormal condition. Please confirm the following precautions:

5-1 Recommended power on/off sequence

*Turn on sequence

- 1) apply input voltage
- 2) apply Vbr and ADIM voltage (recommend low impedance output like operation amplifier output etc.)
- 3) apply remote on/off voltage (recommend high level signal at open collector or logic output)

*Please provide mask for the alarm signal at turn on when you control external product by monitoring alarm output. (Please refer to Fig.5-1: recommended sequence)

*Turn off sequence

- 1) turn off remote on/off voltage(recommend low level signal at open collector or logic output)
- 2) turn off Vbr and ADIM voltage (recommend low impedance output like operation amplifier output etc.)
- 3) turn off input voltage

*Please provide mask for the alarm signal at turn off when you control external product by monitoring alarm output. (Please refer to Fig.5-1: recommended sequence)

5-2 Precaution for Turn on input voltage and remote on/off voltage simultaneously

*Turn on

When input voltage is lower than working voltage of IC, the alarm signal may activate.

When the rise time of input voltage is long, the alarm signal may activate.

*Please provide mask for the alarm signal at turn on when you control external product by monitoring alarm output. (Please refer to Fig.5-1: recommended sequence)

*Turn off

When input voltage is lower than working voltage of IC, alarm signal may activate.

When the fall time of input voltage is long, the alarm signal may activate.

*Please provide mask for the alarm signal at turn off when you control external product by monitoring alarm output. (Please refer to Fig.5-1: recommended sequence)

5-3 Precaution for Turn on or turn off remote control voltage slowly

*Turn on

When the rise time of remote on/off voltage is long, the alarm signal may activate.

We recommend slew rate apply to the remote on/off terminal is faster than 0.1V/usec.

*Turn off

When the fall time of remote on/off voltage is long, the alarm signal may activate.

We recommend that the slew rate applied to the remote on/off terminal is faster than 0.1V/usec.

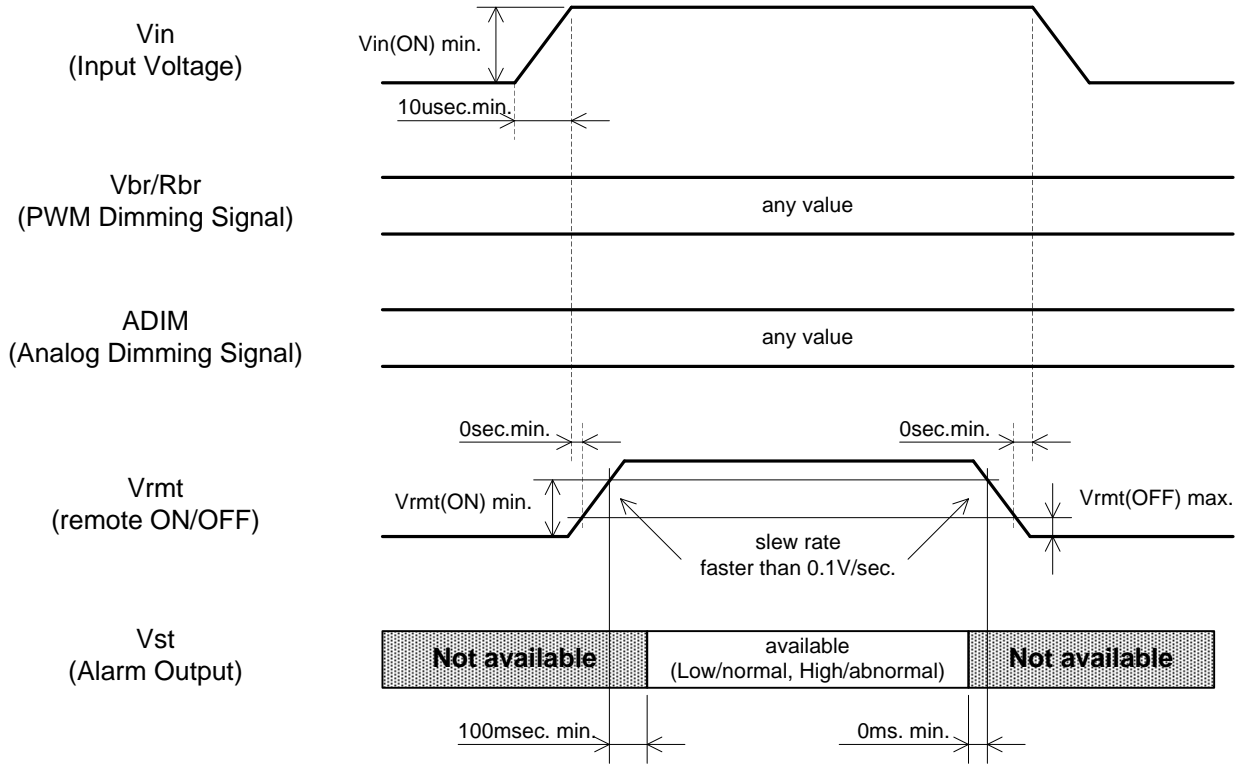

- $V_{in(ON) \text{ min.}}$: minimum of recommended working input voltage
- $V_{rmt(ON) \text{ min.}}$: minimum Vrmt on voltage
- $V_{rmt(OFF) \text{ max.}}$: maximum Vrmt off voltage

Fig.5-1. Recommended Power On/Off Sequence



6 Noise Reduction

*Converter ripple/noise generation summary

- (1) Ripple noise between input terminals
- (2) Switching noise by power lines
- (3) Induction noise by inductor leakage flux

6-1 Ripple Noise between Input Terminals

The Input terminal of the ALD has the following circuit Figures 6-1.

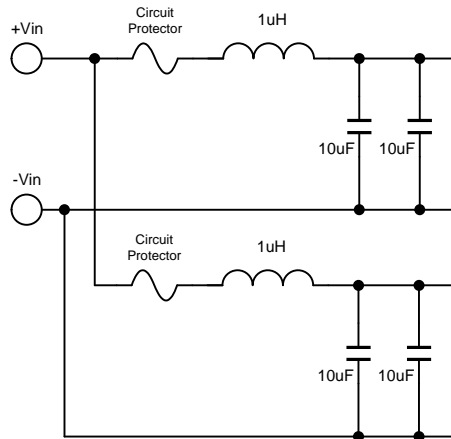

Fig. 6-1 Equivalent input circuit

-type low pass filter is available by attaching an external capacitor to the input terminal. This filter is effective against ripple voltage and current at the input terminal. And this filter is not susceptible to ESR and capacitance because an inductor is on the input line. We evaluate ripple voltage and current as follows:
 We attached a Nippon Chemicon type LXZ35V-1000uF (□12.5,L=20mm) 15cm from the converter. The ripple voltage and current is determined by external capacitance, ESR, wire length and wiring impedance. Please confirm ripple voltage and ripple peak current is within the value described in the Product Drawing before using.

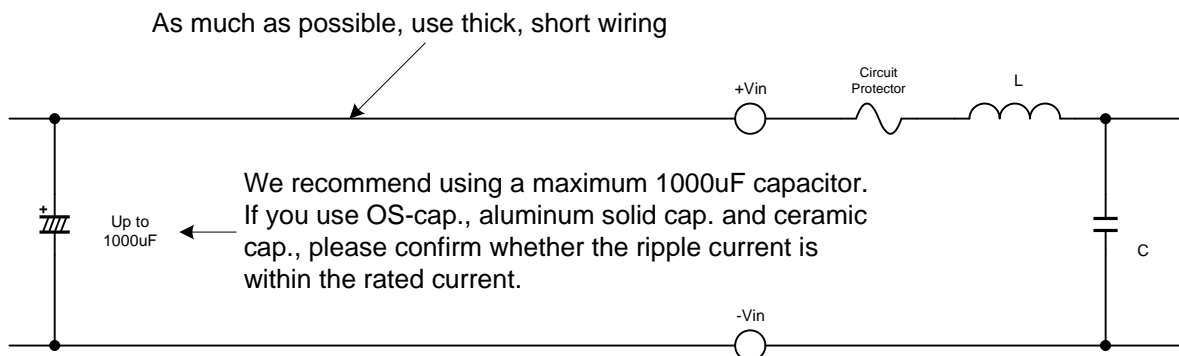

Fig. 6-2 Example of addition of an electrolytic capacitor



6-2 Switching Noise by Main Switch

The ALD adopts the boost up chopper topology.

The switching frequency is around 700kHz. The internal burst dimming (PWM) frequency is about 200Hz.

Noise may appear at basic frequency and odd number times of frequency.

Please confirm that the final set is not affected by this noise.

If the conduction noise level becomes a problem, please insert the low-pass filter, the normal mode filter, and the common mode filter of the multistage configuration in the input side according to the kind of the noise, and please use the clamping filter for the I/O cable to decrease the line noise in the power supply, as shown in Figure 6-3.

If the radiation noise level becomes a problem, please shield or separate the distance from electrical loop with main MOSFET, diode, and capacitor.

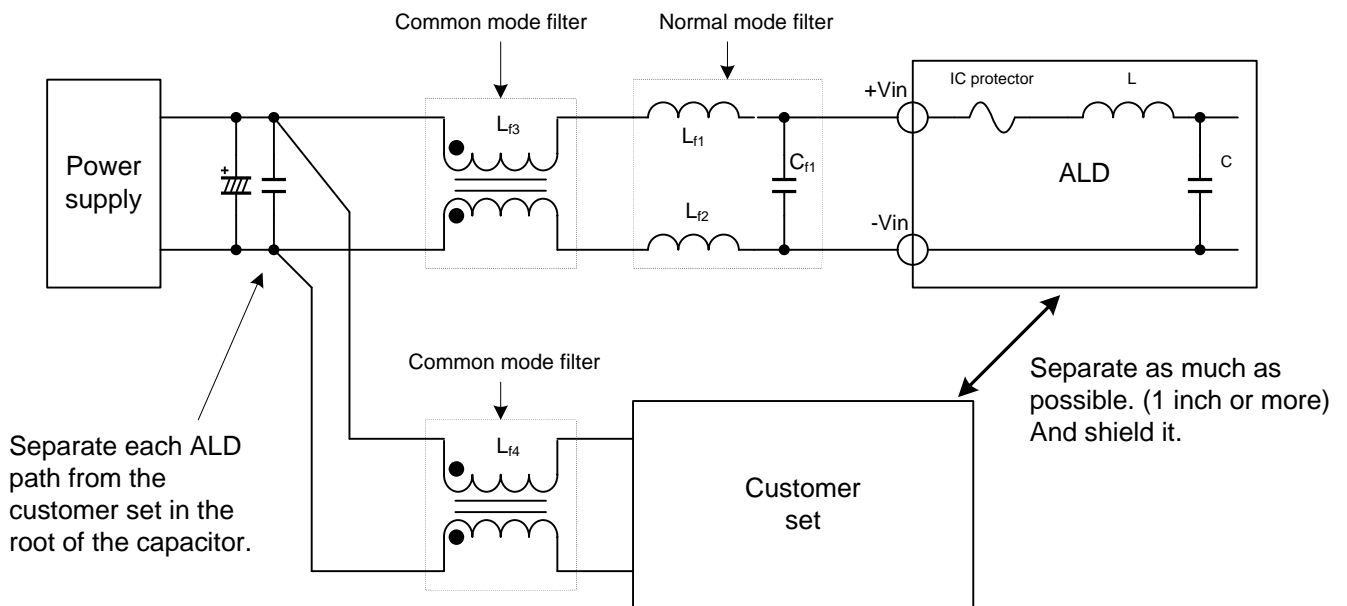

Fig. 6-3 The noise reduction method

A noise measuring method is as follows,

1. Remove the clip from the probe head. In order to minimize the loop of signal- GND. However, there is a possibility that the noise gets on according to the measuring method.
2. Measure it with the following cables,
JEITA(Japan Electronics and Information Technology Industries Association), RC9141, 7.13 Fig.C
<http://www.jeita.or.jp/english/>

We use the measuring method of 2.

6-3 Induction Noise by Inductor Leakage Flux

In the ALD, the choke inductor is the component that generates leakage flux.

The inductor may affect the high impedance line of near field because of the huge leakage flux.

Please be careful do not place signal path near field of inductor.

And if you shield leakage flux by high permeability material at close range of inductor top, eddy current losses by leakage flux occurs. As a result, it reduces circuit efficiency and causes unexpected heat up.

Please be sure to keep enough space between shield materials and the inductor.



9 Other Caution

9-1 Input terminal connection considerations

- *The Vbr terminal has a low internal impedance setting in order to dim by resistor. If you apply voltage to the Vbr terminal, we recommend a voltage follower connection or a low output impedance connection. When you have no choice but to connect a high impedance circuit to Vbr terminal, please consider Vbr input impedance.
- *When the Vst terminal of an alarm output is used, please take into consideration the equivalent circuit of the Vst terminal indicated in product specification.
- *Please avoid to control dimming by Vrmt terminal. When you want to use dimming, please use Vbr or ADIM terminal.
- *This unit does not allow hot plugging. When the unit is operating do not plug in or plug out the connector.
- *If the same connector as CN1 is plugged repeatedly, lout sometimes changes under the influence of contact resistance.
- *When you handle the unit, please be careful to keep unit's components from coming in contact with anything.

9-2 Flicker Considerations

- *In PWM or Analog Dimming operation, please confirm whether there is any flicker of the LCD panel prospectively. Flickering may occur due to ripple noise is on Dimming pin (Vbr / Rbr / ADIM).

9-3 Dimming Sound Noise Considerations

- *In PWM Dimming operation, please confirm LCD panel operation prospectively. Noise may occur according to the state of the substrate installation when the PWM Dimming pin (Vbr / Rbr) is used.

9-4 Converter Layout Considerations

- *Please consider unit's layout to prevent long cabling.
- *In order to protect the ALD against vibration and shock, be sure to use all mounting holes when installing the ALD.
- *Please confirm the clearance between screw head and layout pattern.
- *Please do not put the unit on top of the back light directly without isolation.
- *If all the GND vias connected with the frame of LCD panel electrically, EMI may decrease.
- *If you operate LCD backlight at floating, the converter may be damaged by contact discharge on the LCD.

Fig. 3-7

